

# TL081 TL081A - TL081B

## GENERAL PURPOSE J-FET SINGLE OPERATIONAL AMPLIFIERS

- WIDE COMMON-MODE (UP TO  $V_{CC}^+$ ) AND DIFFERENTIAL VOLTAGE RANGE
- LOW INPUT BIAS AND OFFSET CURRENT
- OUTPUT SHORT-CIRCUIT PROTECTION
- HIGH INPUT IMPEDANCE J-FET INPUT STAGE
- INTERNAL FREQUENCY COMPENSATION
- LATCH UP FREE OPERATION
- HIGH SLEW RATE : 16V/ $\mu$ s (typ)

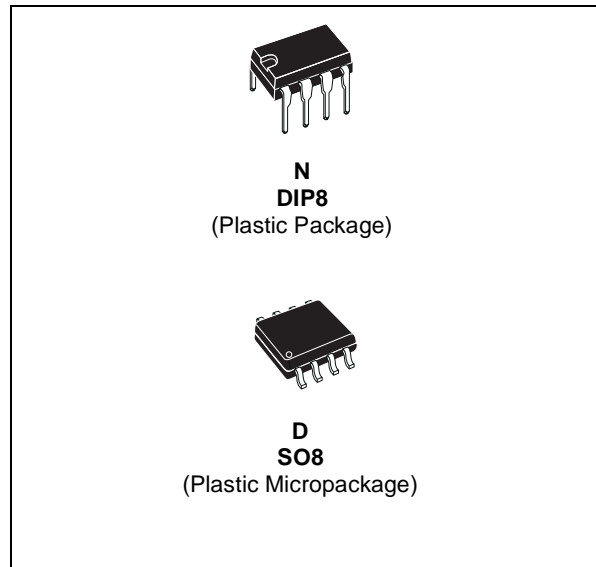

### DESCRIPTION

The TL081, TL081A and TL081B are high speed J-FET input single operational amplifiers incorporating well matched, high voltage J-FET and bipolar transistors in a monolithic integrated circuit.

The devices feature high slew rates, low input bias and offset currents, and low offset voltage temperature coefficient.

### PIN CONNECTIONS (top view)

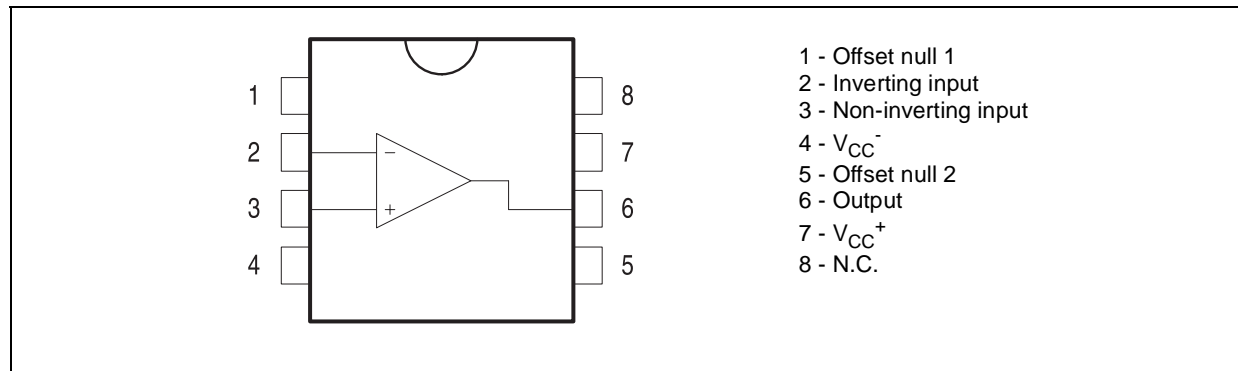

### ORDER CODE

Part Number	Temperature Range	Package	
		N	D
TL081M/AM/BM	-55°C, +125°C	•	•
TL081I/AI/BI	-40°C, +105°C	•	•
TL081C/AC/BC	0°C, +70°C	•	•

**Example :** TL081CD, TL081IN

**N** = Dual in Line Package (DIP)  
**D** = Small Outline Package (SO) - also available in Tape & Reel (DT)

**SCHEMATIC DIAGRAM**

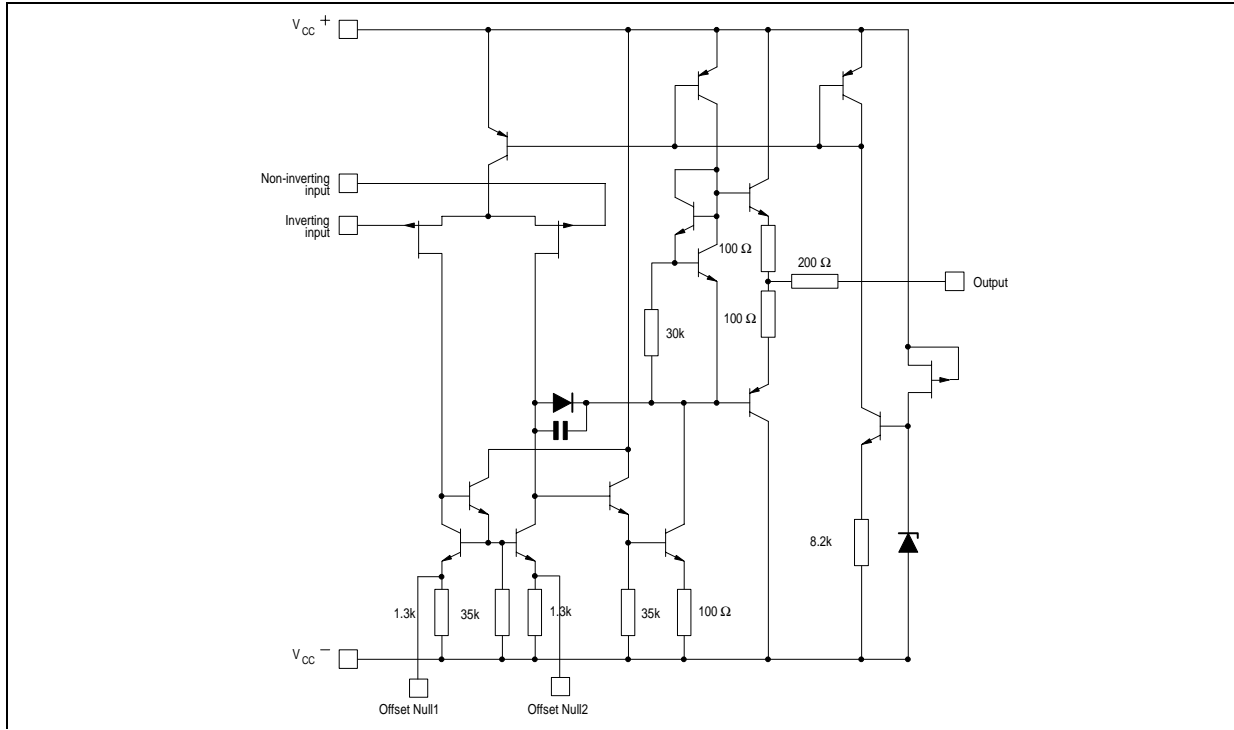

**INPUT OFFSET VOLTAGE NULL CIRCUIT**

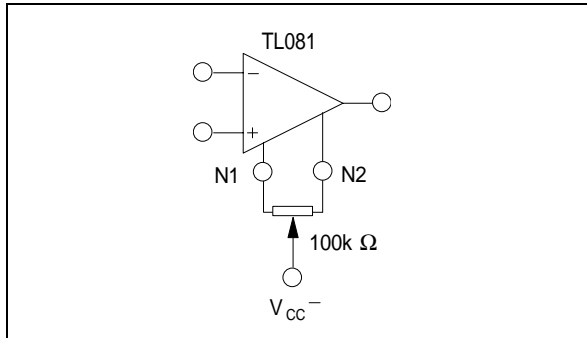

**ABSOLUTE MAXIMUM RATINGS**

Symbol	Parameter	TL081M, AM, BM	TL081I, AI, BI	TL081C, AC, BC	Unit
$V_{CC}$	Supply voltage - note 1)	±18			V
$V_i$	Input Voltage - note 2)	±15			V
$V_{id}$	Differential Input Voltage - note 3)	±30			V
$P_{tot}$	Power Dissipation	680			mW
	Output Short-circuit Duration - note 4)	Infinite			
$T_{oper}$	Operating Free-air Temperature Range	-55 to +125	-40 to +105	0 to +70	°C
$T_{stg}$	Storage Temperature Range	-65 to +150			°C

1. All voltage values, except differential voltage, are with respect to the zero reference level (ground) of the supply voltages where the zero reference level is the midpoint between  $V_{CC}^+$  and  $V_{CC}^-$ .
2. The magnitude of the input voltage must never exceed the magnitude of the supply voltage or 15 volts, whichever is less.
3. Differential voltages are the non-inverting input terminal with respect to the inverting input terminal.
4. The output may be shorted to ground or to either supply. Temperature and/or supply voltages must be limited to ensure that the dissipation rating is not exceeded.

**ELECTRICAL CHARACTERISTICS**

$V_{CC} = \pm 15V$ ,  $T_{amb} = +25^{\circ}C$  (unless otherwise specified)

Symbol	Parameter	TL081,M,AC,AI,AM, BC,BI,BM			TL081C			Unit
		Min.	Typ.	Max.	Min.	Typ.	Max.	
$V_{io}$	Input Offset Voltage ( $R_S = 50\Omega$ ) $T_{amb} = +25^{\circ}C$ $T_{min} \leq T_{amb} \leq T_{max}$		3 3 1	10 6 3 13 7 5		3 10		mV
$DV_{io}$	Input Offset Voltage Drift		10			10		$\mu V/^{\circ}C$
$I_{io}$	Input Offset Current - note 1) $T_{amb} = +25^{\circ}C$ $T_{min} \leq T_{amb} \leq T_{max}$		5	100 4		5 100		pA nA
$I_{ib}$	Input Bias Current -note 1 $T_{amb} = +25^{\circ}C$ $T_{min} \leq T_{amb} \leq T_{max}$		20	200 20		20 400		nA
$A_{vd}$	Large Signal Voltage Gain ( $R_L = 2k\Omega$ , $V_o = \pm 10V$ ) $T_{amb} = +25^{\circ}C$ $T_{min} \leq T_{amb} \leq T_{max}$	50 25	200		25 15	200		V/mV
SVR	Supply Voltage Rejection Ratio ( $R_S = 50\Omega$ ) $T_{amb} = +25^{\circ}C$ $T_{min} \leq T_{amb} \leq T_{max}$	80 80	86		70 70	86		dB
$I_{CC}$	Supply Current, no load $T_{amb} = +25^{\circ}C$ $T_{min} \leq T_{amb} \leq T_{max}$		1.4	2.5 2.5		1.4 2.5		mA
$V_{icm}$	Input Common Mode Voltage Range	$\pm 11$	+15 -12		$\pm 11$	+15 -12		V
CMR	Common Mode Rejection Ratio ( $R_S = 50\Omega$ ) $T_{amb} = +25^{\circ}C$ $T_{min} \leq T_{amb} \leq T_{max}$	80 80	86		70 70	86		dB
$I_{os}$	Output Short-circuit Current $T_{amb} = +25^{\circ}C$ $T_{min} \leq T_{amb} \leq T_{max}$	10 10	40	60 60	10 10	40 60		mA
$\pm V_{opp}$	Output Voltage Swing $T_{amb} = +25^{\circ}C$ $T_{min} \leq T_{amb} \leq T_{max}$		10 12 10 12	12 13.5		10 12 10 12		V
SR	Slew Rate ( $T_{amb} = +25^{\circ}C$ ) $V_{in} = 10V$ , $R_L = 2k\Omega$ , $C_L = 100pF$ , unity gain		8	16		8 16		V/ $\mu s$
$t_r$	Rise Time ( $T_{amb} = +25^{\circ}C$ ) $V_{in} = 20mV$ , $R_L = 2k\Omega$ , $C_L = 100pF$ , unity gain			0.1		0.1		$\mu s$
$K_{ov}$	Overshoot ( $T_{amb} = +25^{\circ}C$ ) $V_{in} = 20mV$ , $R_L = 2k\Omega$ , $C_L = 100pF$ , unity gain			10		10		%
GBP	Gain Bandwidth Product ( $T_{amb} = +25^{\circ}C$ ) $V_{in} = 10mV$ , $R_L = 2k\Omega$ , $C_L = 100pF$ , $f = 100kHz$		2.5	4		2.5 4		MHz
$R_i$	Input Resistance			$10^{12}$		$10^{12}$		$\Omega$

**TL081 - TL081A - TL081B**

Symbol	Parameter	TL081I,M,AC,AI,AM, BC,BI,BM			TL081C			Unit
		Min.	Typ.	Max.	Min.	Typ.	Max.	
THD	Total Harmonic Distortion ( $T_{amb} = +25^{\circ}\text{C}$ ), $f = 1\text{kHz}$ , $R_L = 2\text{k}\Omega$ , $C_L = 100\text{pF}$ , $A_v = 20\text{dB}$ , $V_o = 2V_{pp}$		0.01			0.01		%
$e_n$	Equivalent Input Noise Voltage $R_S = 100\Omega$ , $f = 1\text{KHz}$		15			15		$\frac{\text{nV}}{\sqrt{\text{Hz}}}$
$\phi_m$	Phase Margin		45			45		degrees

1. The input bias currents are junction leakage currents which approximately double for every 10°C increase in the junction temperature.

**MAXIMUM PEAK-TO-PEAK OUTPUT VOLTAGE versus FREQUENCY**

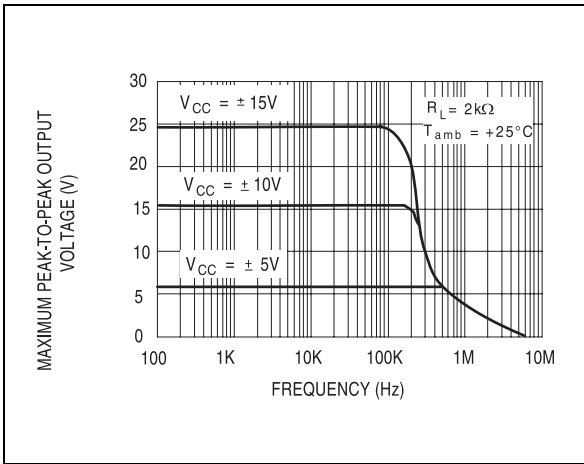

**MAXIMUM PEAK-TO-PEAK OUTPUT VOLTAGE versus FREQUENCY**

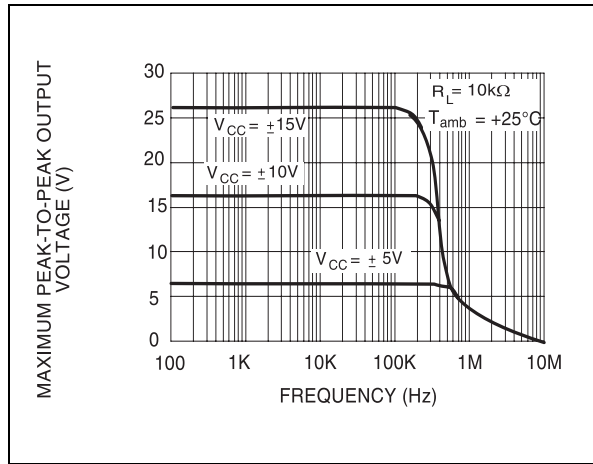

**MAXIMUM PEAK-TO-PEAK OUTPUT VOLTAGE versus FREQUENCY**

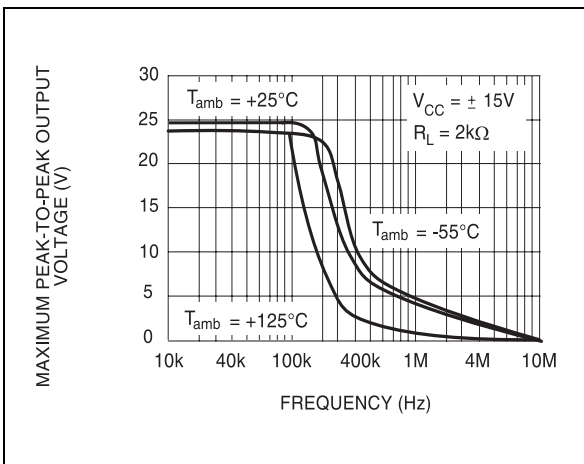

**MAXIMUM PEAK-TO-PEAK OUTPUT VOLTAGE versus FREE AIR TEMP.**

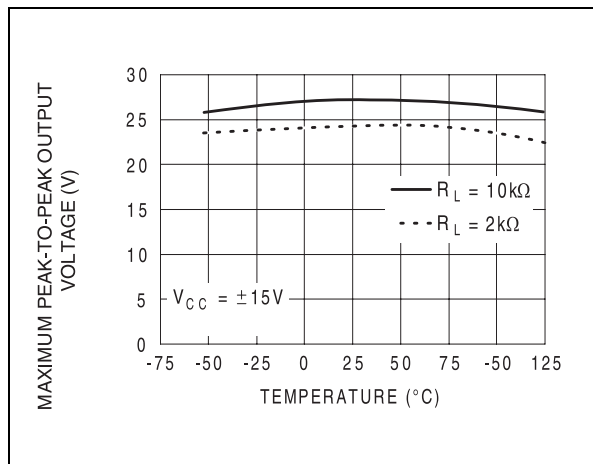

**MAXIMUM PEAK-TO-PEAK OUTPUT VOLTAGE versus LOAD RESISTANCE**

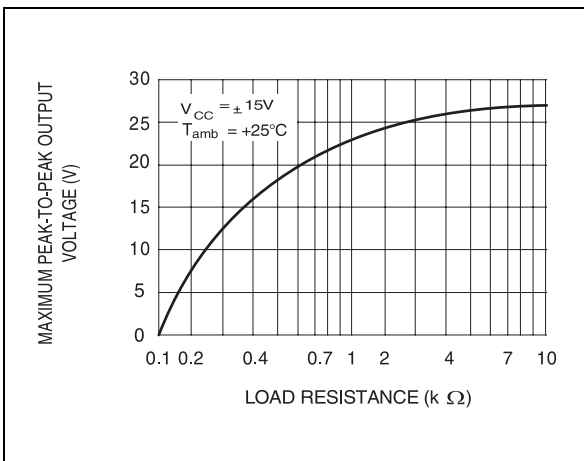

**MAXIMUM PEAK-TO-PEAK OUTPUT VOLTAGE versus SUPPLY VOLTAGE**

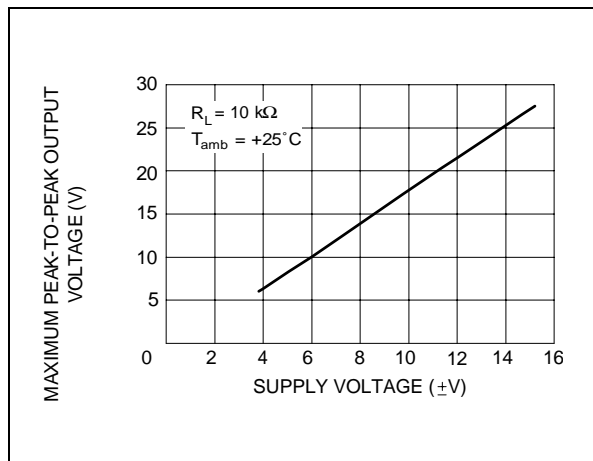

**INPUT BIAS CURRENT versus FREE AIR TEMPERATURE**

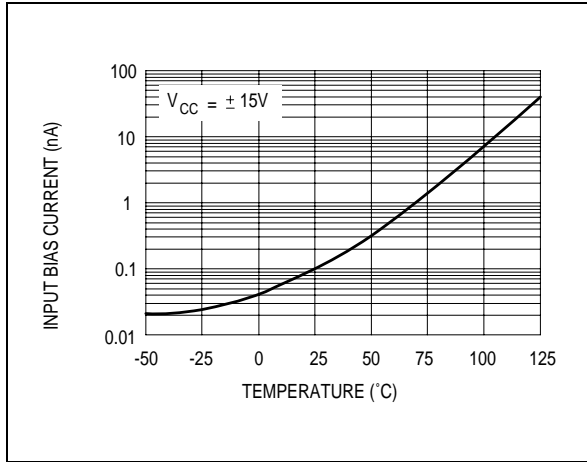

**LARGE SIGNAL DIFFERENTIAL VOLTAGE AMPLIFICATION versus FREE AIR TEMP.**

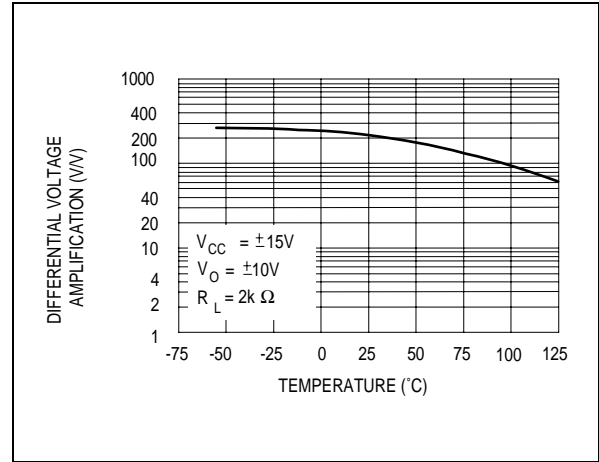

**LARGE SIGNAL DIFFERENTIAL VOLTAGE AMPLIFICATION AND PHASE SHIFT versus FREQUENCY**

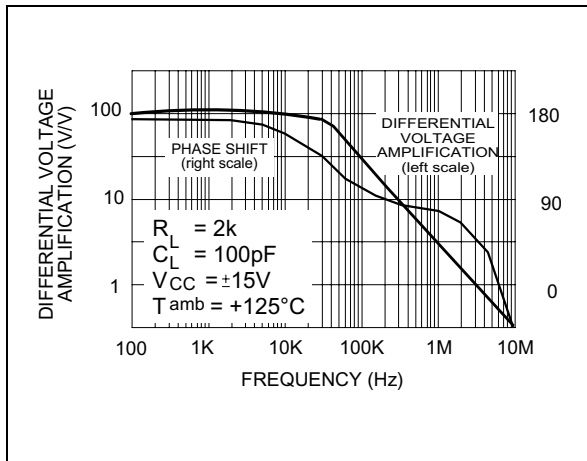

**TOTAL POWER DISSIPATION versus FREE AIR TEMPERATURE**

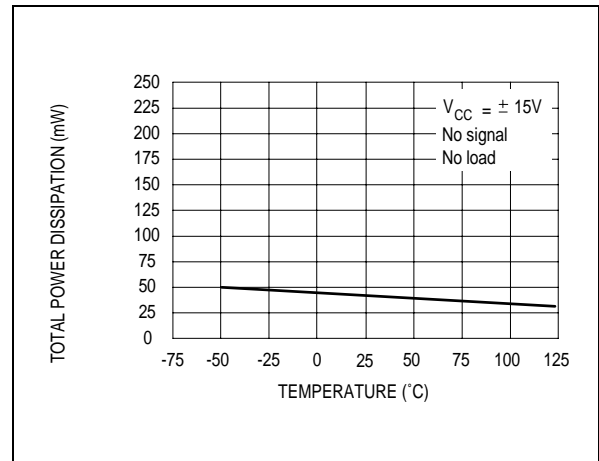

**SUPPLY CURRENT PER AMPLIFIER versus FREE AIR TEMPERATURE**

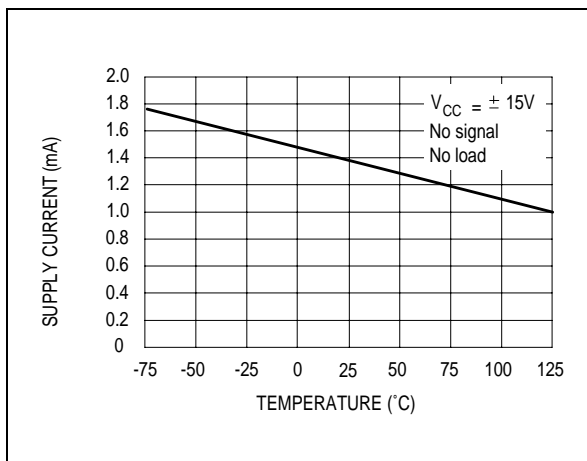

**SUPPLY CURRENT PER AMPLIFIER versus SUPPLY VOLTAGE**

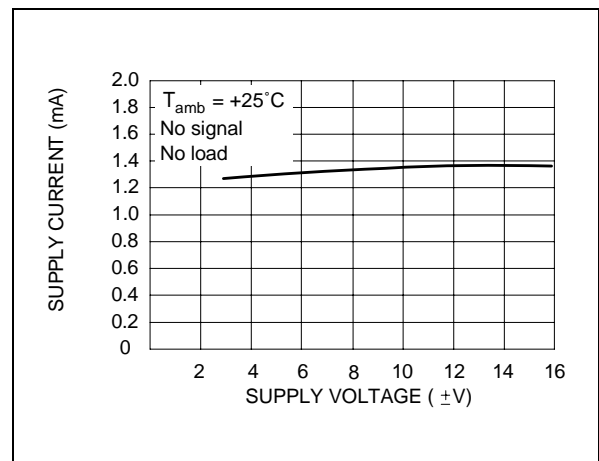

**COMMON MODE REJECTION RATIO versus FREE AIR TEMPERATURE**

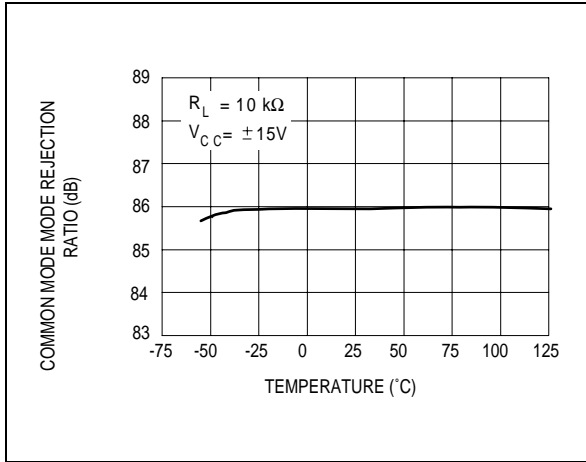

**VOLTAGE FOLLOWER LARGE SIGNAL PULSE RESPONSE**

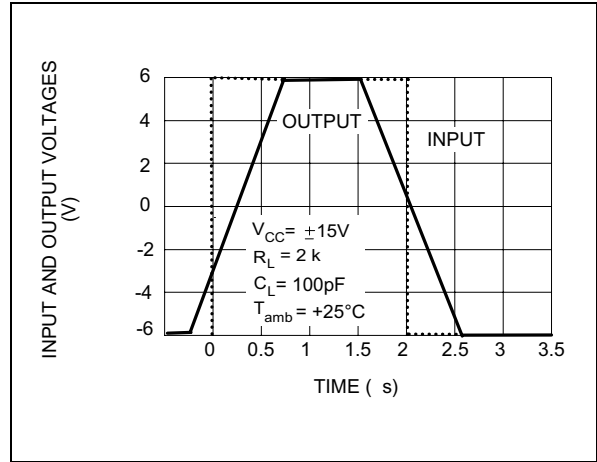

**OUTPUT VOLTAGE versus ELAPSED TIME**

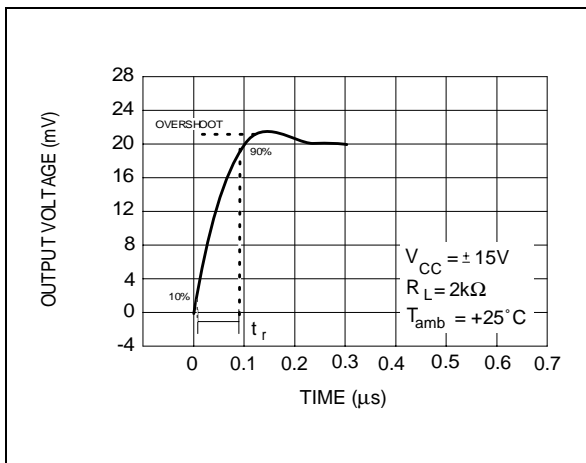

**EQUIVALENT INPUT NOISE VOLTAGE versus FREQUENCY**

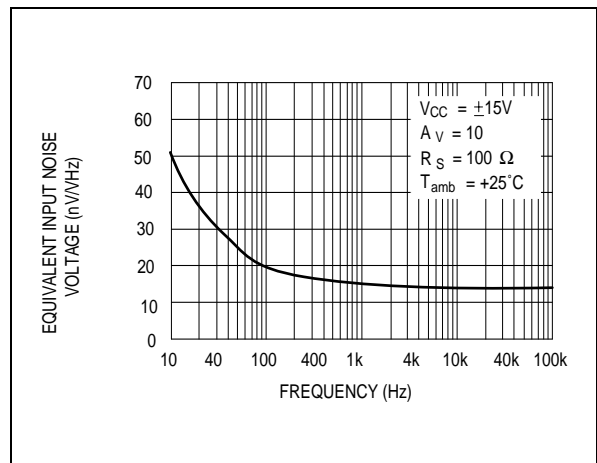

**TOTAL HARMONIC DISTORTION versus FREQUENCY**

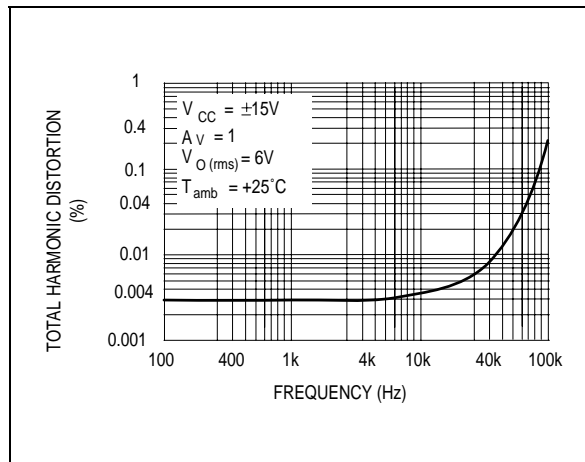

PARAMETER MEASUREMENT INFORMATION

Figure 1 : Voltage Follower

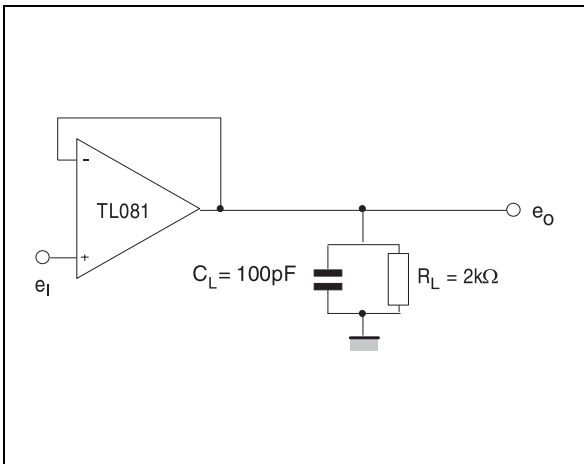
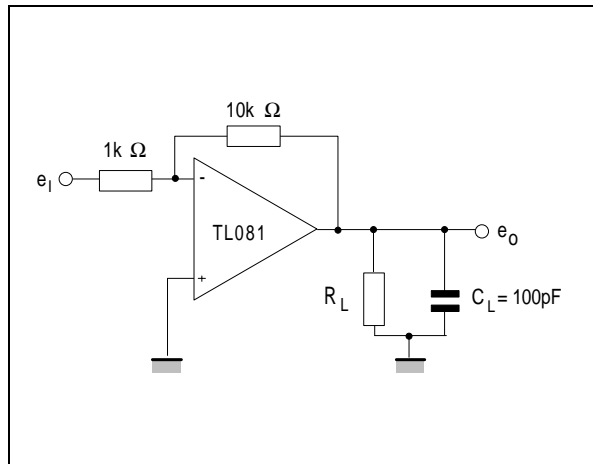
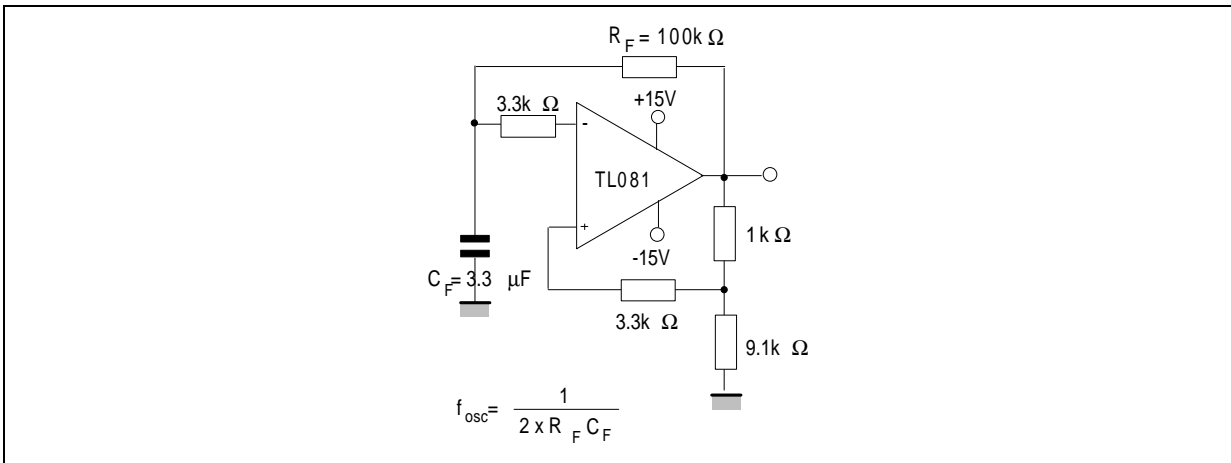

Figure 2 : Gain-of-10 Inverting Amplifier



TYPICAL APPLICATIONS

(0.5Hz) SQUARE WAVE OSCILLATOR



HIGH Q NOTCH FILTER

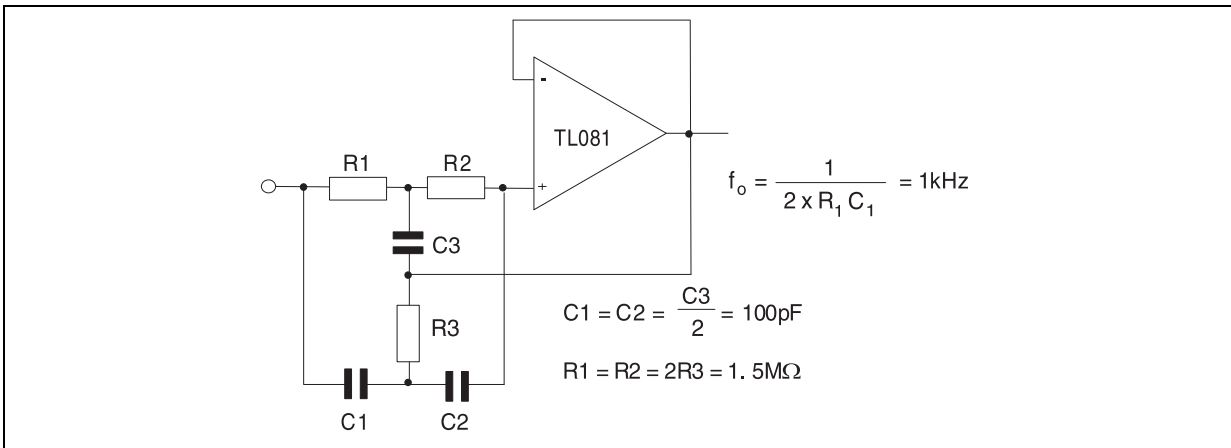

**PACKAGE MECHANICAL DATA**  
8 PINS - PLASTIC DIP

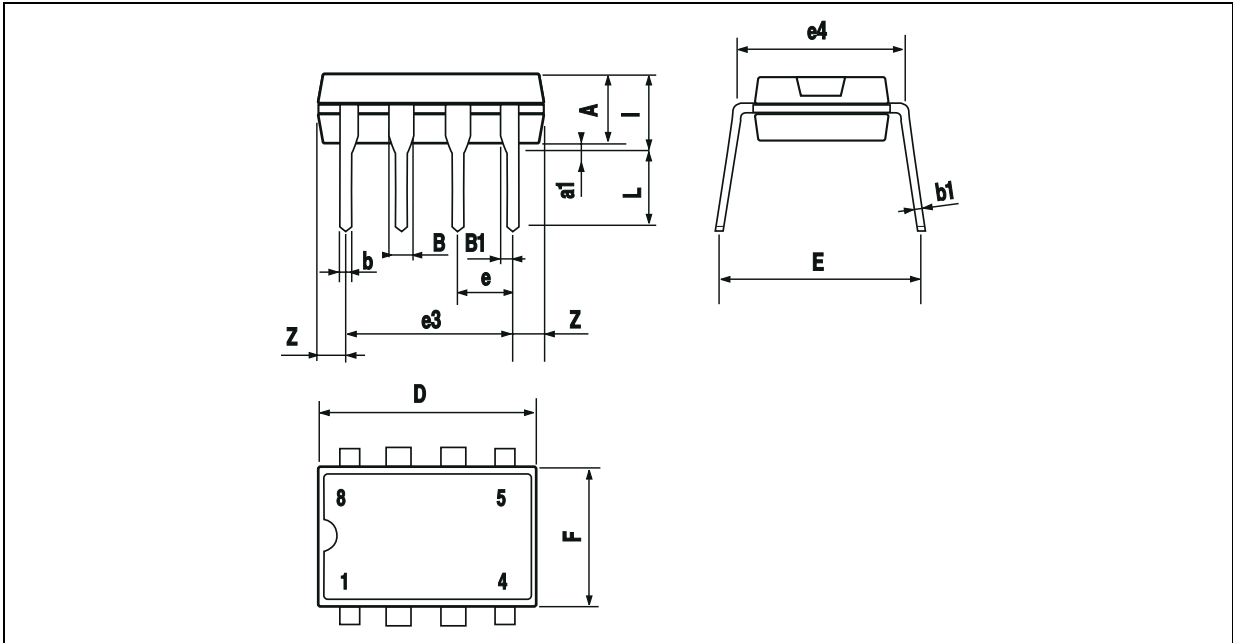

Dim.	Millimeters			Inches		
	Min.	Typ.	Max.	Min.	Typ.	Max.
A		3.32			0.131	
a1	0.51			0.020		
B	1.15		1.65	0.045		0.065
b	0.356		0.55	0.014		0.022
b1	0.204		0.304	0.008		0.012
D			10.92			0.430
E	7.95		9.75	0.313		0.384
e		2.54			0.100	
e3		7.62			0.300	
e4		7.62			0.300	
F			6.6			0.260
i			5.08			0.200
L	3.18		3.81	0.125		0.150
Z			1.52			0.060

**TL081 - TL081A - TL081B**

**PACKAGE MECHANICAL DATA**  
**8 PINS - PLASTIC MICROPACKAGE (SO)**

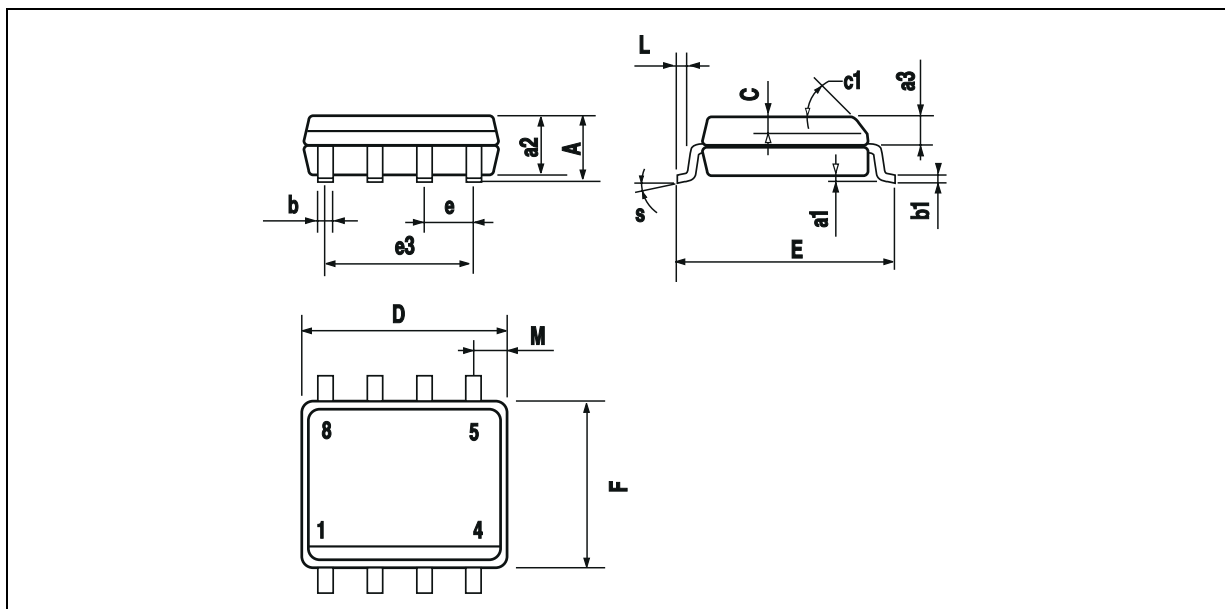

Dim.	Millimeters			Inches		
	Min.	Typ.	Max.	Min.	Typ.	Max.
A			1.75			0.069
a1	0.1		0.25	0.004		0.010
a2			1.65			0.065
a3	0.65		0.85	0.026		0.033
b	0.35		0.48	0.014		0.019
b1	0.19		0.25	0.007		0.010
C	0.25		0.5	0.010		0.020
c1	45° (typ.)					
D	4.8		5.0	0.189		0.197
E	5.8		6.2	0.228		0.244
e		1.27			0.050	
e3		3.81			0.150	
F	3.8		4.0	0.150		0.157
L	0.4		1.27	0.016		0.050
M			0.6			0.024
S	8° (max.)					