

## LM108/LM208/LM308 Operational Amplifiers

### General Description

The LM108 series are precision operational amplifiers having specifications a factor of ten better than FET amplifiers over a  $-55^{\circ}\text{C}$  to  $+125^{\circ}\text{C}$  temperature range.

The devices operate with supply voltages from  $\pm 2\text{V}$  to  $\pm 20\text{V}$  and have sufficient supply rejection to use unregulated supplies. Although the circuit is interchangeable with and uses the same compensation as the LM101A, an alternate compensation scheme can be used to make it particularly insensitive to power supply noise and to make supply bypass capacitors unnecessary.

The low current error of the LM108 series makes possible many designs that are not practical with conventional amplifiers. In fact, it operates from  $10\text{ M}\Omega$  source resistances,

introducing less error than devices like the 709 with  $10\text{ k}\Omega$  sources. Integrators with drifts less than  $500\ \mu\text{V}/\text{sec}$  and analog time delays in excess of one hour can be made using capacitors no larger than  $1\ \mu\text{F}$ .

The LM108 is guaranteed from  $-55^{\circ}\text{C}$  to  $+125^{\circ}\text{C}$ , the LM208 from  $-25^{\circ}\text{C}$  to  $+85^{\circ}\text{C}$ , and the LM308 from  $0^{\circ}\text{C}$  to  $+70^{\circ}\text{C}$ .

### Features

- Maximum input bias current of  $3.0\ \text{nA}$  over temperature
- Offset current less than  $400\ \text{pA}$  over temperature
- Supply current of only  $300\ \mu\text{A}$ , even in saturation
- Guaranteed drift characteristics

### Compensation Circuits

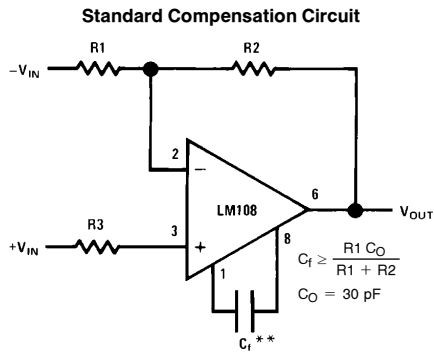

TL/H/7758-1

\*\*Bandwidth and slew rate are proportional to  $1/C_f$

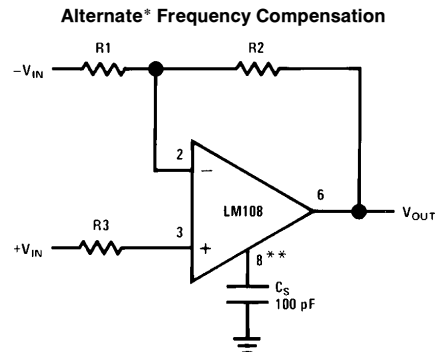

TL/H/7758-2

\*Improves rejection of power supply noise by a factor of ten.

\*\*Bandwidth and slew rate are proportional to  $1/C_s$

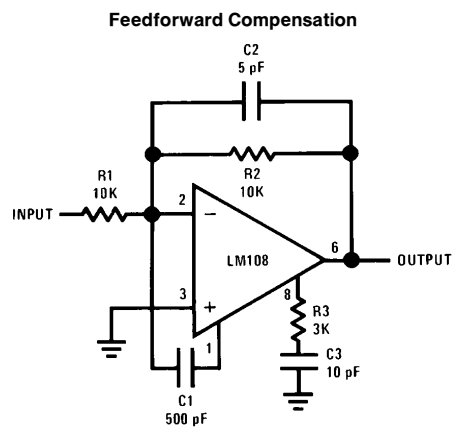

TL/H/7758-3

## Absolute Maximum Ratings

If Military/Aerospace specified devices are required, please contact the National Semiconductor Sales Office/Distributors for availability and specifications.  
(Note 5)

|   | LM108/LM208      | LM308            |
|---|------------------|------------------|
| Supply Voltage  | ± 20V            | ± 18V            |
| Power Dissipation (Note 1)  | 500 mW           | 500 mW           |
| Differential Input Current (Note 2)   | ± 10 mA          | ± 10 mA          |
| Input Voltage (Note 3)  | ± 15V            | ± 15V            |
| Output Short-Circuit Duration   | Continuous       | Continuous       |
| Operating Temperature Range (LM108)   | −55°C to + 125°C | 0°C to + 70°C    |
| (LM208)   | −25°C to + 85°C  |                  |
| Storage Temperature Range   | −65°C to + 150°C | −65°C to + 150°C |
| Lead Temperature (Soldering, 10 sec)  |                  |                  |
| DIP   | 260°C            | 260°C            |
| H Package Lead Temp   |                  |                  |
| (Soldering 10 seconds)  | 300°C            | 300°C            |
| Soldering Information   |                  |                  |
| Dual-In-Line Package  |                  |                  |
| Soldering (10 seconds)  | 260°C            |                  |
| Small Outline Package   |                  |                  |
| Vapor Phase (60 seconds)  | 215°C            |                  |
| Infrared (15 seconds)   | 220°C            |                  |
| See AN-450 "Surface Mounting Methods and Their Effect on Product Reliability" for other methods of soldering surface mount devices. |                  |                  |
| ESD Tolerance (Note 6)  | 2000V            |                  |

## Electrical Characteristics (Note 4)

| Parameter   | Condition  | LM108/LM208 |      |     | LM308 |      |     | Units                        |
|---|--|-------------|------|-----|-------|------|-----|------------------------------|
|   |  | Min         | Typ  | Max | Min   | Typ  | Max |                              |
| Input Offset Voltage                                    | $T_A = 25^\circ\text{C}$   |             | 0.7  | 2.0 |       | 2.0  | 7.5 | mV                           |
| Input Offset Current                                    | $T_A = 25^\circ\text{C}$   |             | 0.05 | 0.2 |       | 0.2  | 1   | nA                           |
| Input Bias Current                                      | $T_A = 25^\circ\text{C}$   |             | 0.8  | 2.0 |       | 1.5  | 7   | nA                           |
| Input Resistance  | $T_A = 25^\circ\text{C}$   | 30          | 70   |     | 10    | 40   |     | MΩ                           |
| Supply Current  | $T_A = 25^\circ\text{C}$   |             | 0.3  | 0.6 |       | 0.3  | 0.8 | mA                           |
| Large Signal Voltage Gain                               | $T_A = 25^\circ\text{C}, V_S = \pm 15\text{V}$<br>$V_{OUT} = \pm 10\text{V}, R_L \geq 10\text{ k}\Omega$ | 50          | 300  |     | 25    | 300  |     | V/mV                         |
| Input Offset Voltage                                    |  |             |      | 3.0 |       |      | 10  | mV                           |
| Average Temperature Coefficient of Input Offset Voltage |  |             | 3.0  | 15  |       | 6.0  | 30  | $\mu\text{V}/^\circ\text{C}$ |
| Input Offset Current                                    |  |             |      | 0.4 |       |      | 1.5 | nA                           |
| Average Temperature Coefficient of Input Offset Current |  |             | 0.5  | 2.5 |       | 2.0  | 10  | $\text{pA}/^\circ\text{C}$   |
| Input Bias Current                                      |  |             |      | 3.0 |       |      | 10  | nA                           |
| Supply Current  | $T_A = +125^\circ\text{C}$   |             | 0.15 | 0.4 |       |      |     | mA                           |
| Large Signal Voltage Gain                               | $V_S = \pm 15\text{V}, V_{OUT} = \pm 10\text{V}$<br>$R_L \geq 10\text{ k}\Omega$                         | 25          |      |     | 15    |      |     | V/mV                         |
| Output Voltage Swing                                    | $V_S = \pm 15\text{V}, R_L = 10\text{ k}\Omega$  | ± 13        | ± 14 |     | ± 13  | ± 14 |     | V                            |

## Electrical Characteristics (Note 4) (Continued)

| Parameter                      | Condition       | LM108/LM208 |     |     | LM308    |     |     | Units |
|--------------------------------|-----------------|-------------|-----|-----|----------|-----|-----|-------|
|                                |                 | Min         | Typ | Max | Min      | Typ | Max |       |
| Input Voltage Range            | $V_S = \pm 15V$ | $\pm 13.5$  |     |     | $\pm 14$ |     |     | V     |
| Common Mode Rejection Ratio    |                 | 85          | 100 |     | 80       | 100 |     | dB    |
| Supply Voltage Rejection Ratio |                 | 80          | 96  |     | 80       | 96  |     | dB    |

**Note 1:** The maximum junction temperature of the LM108 is 150°C, for the LM208, 100°C and for the LM308, 85°C. For operating at elevated temperatures, devices in the H08 package must be derated based on a thermal resistance of 160°C/W, junction to ambient, or 20°C/W, junction to case. The thermal resistance of the dual-in-line package is 100°C/W, junction to ambient.

**Note 2:** The inputs are shunted with back-to-back diodes for overvoltage protection. Therefore, excessive current will flow if a differential input voltage in excess of 1V is applied between the inputs unless some limiting resistance is used.

**Note 3:** For supply voltages less than  $\pm 15V$ , the absolute maximum input voltage is equal to the supply voltage.

**Note 4:** These specifications apply for  $\pm 5V \leq V_S \leq \pm 20V$  and  $-55^\circ C \leq T_A \leq +125^\circ C$ , unless otherwise specified. With the LM208, however, all temperature specifications are limited to  $-25^\circ C \leq T_A \leq 85^\circ C$ , and for the LM308 they are limited to  $0^\circ C \leq T_A \leq 70^\circ C$ .

**Note 5:** Refer to RETS108X for LM108 military specifications and RETs 108AX for LM108A military specifications.

**Note 6:** Human body model, 1.5 k $\Omega$  in series with 100 pF.

## Schematic Diagram

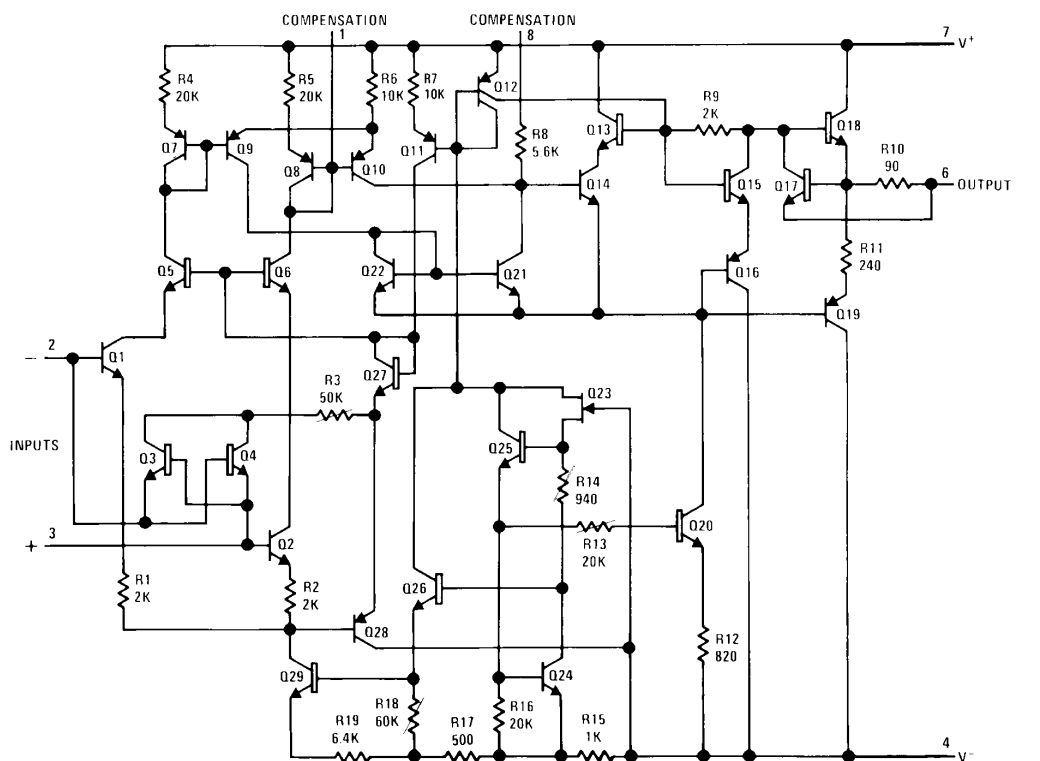

TL/H/7758-8

# Typical Performance Characteristics LM108/LM208

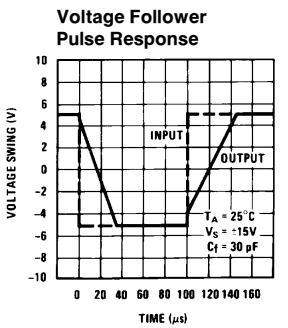
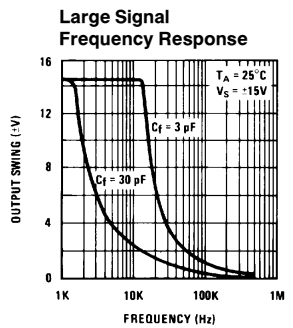
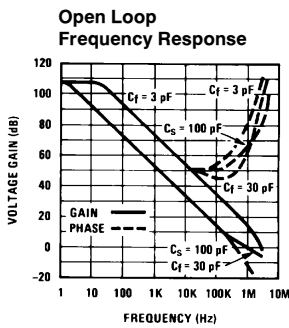
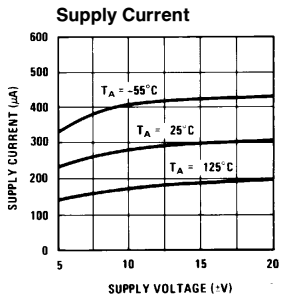
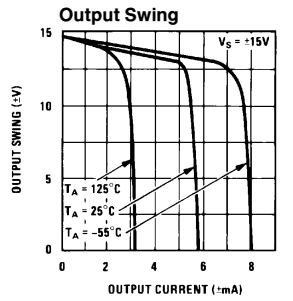
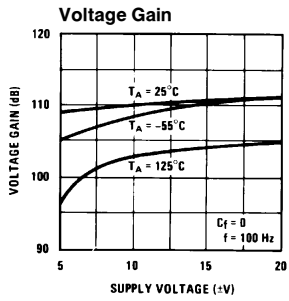
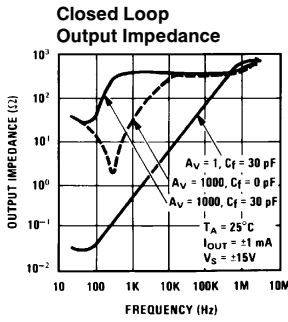
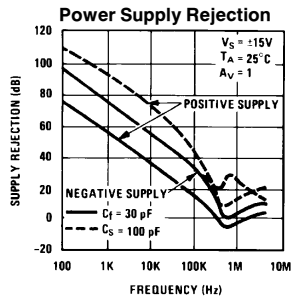
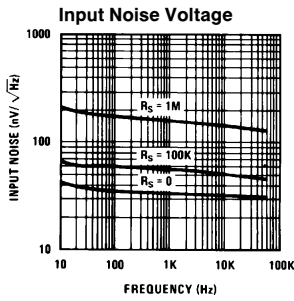
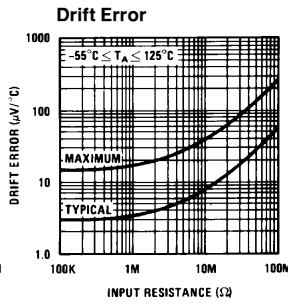
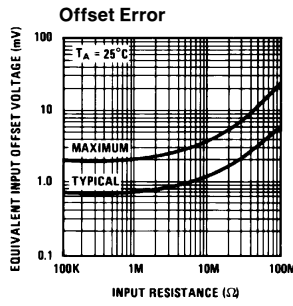
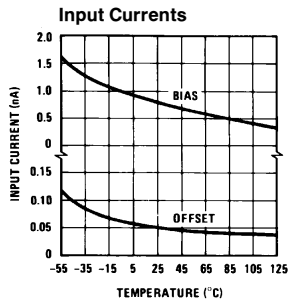

TL/H/7758-6

# Typical Performance Characteristics LM308

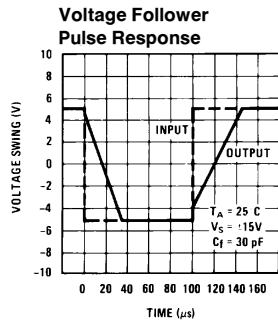
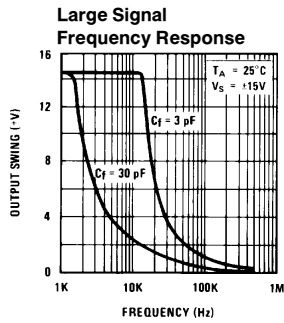
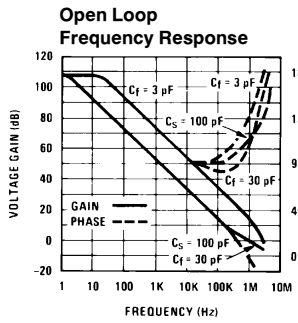
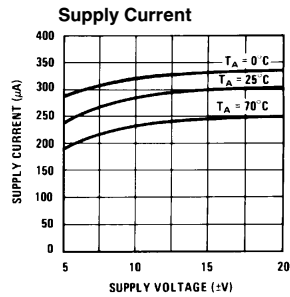
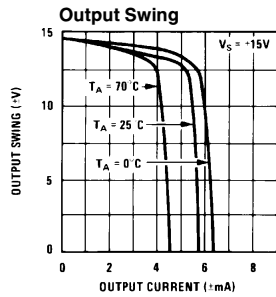
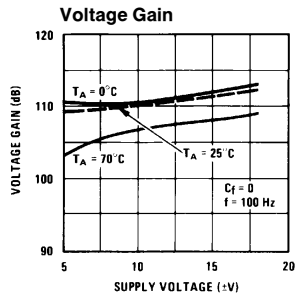
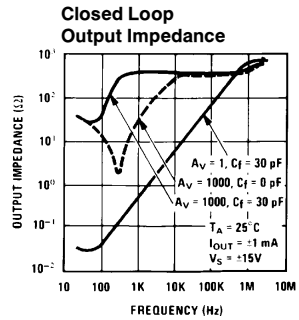
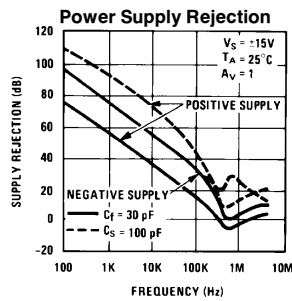
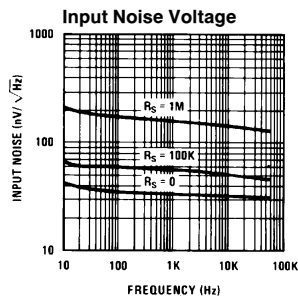
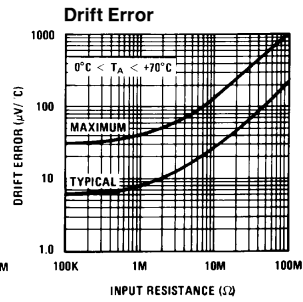
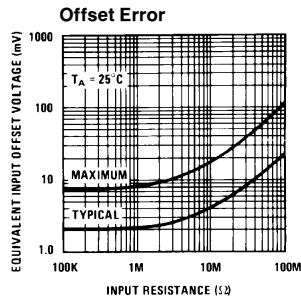
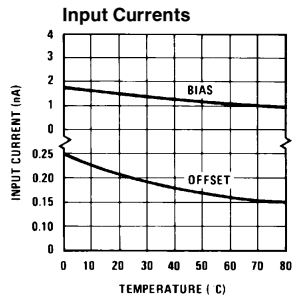

TL/H/7758-7

# Typical Applications

**Sample and Hold**

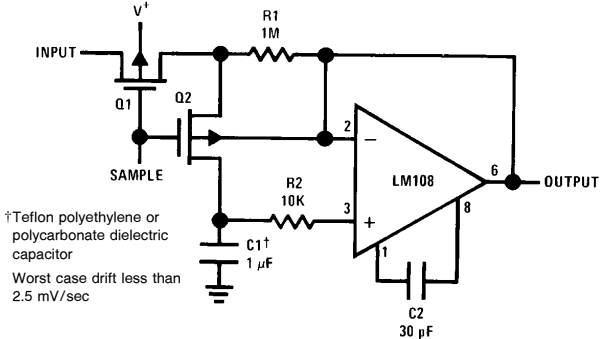

TL/H/7758-4

**High Speed Amplifier with Low Drift and Low Input Current**

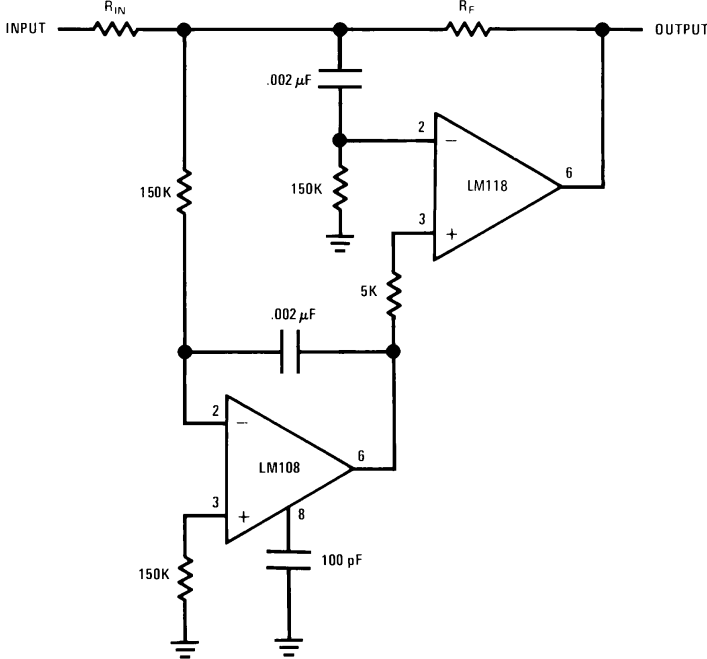

TL/H/7758-5

## Typical Applications (Continued)

### Fast† Summing Amplifier

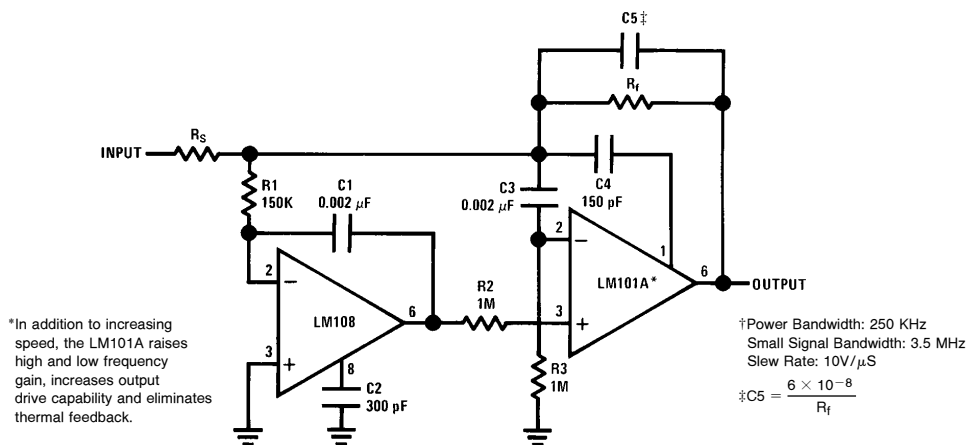

TL/H/7758-12

## Connection Diagrams

### Metal Can Package

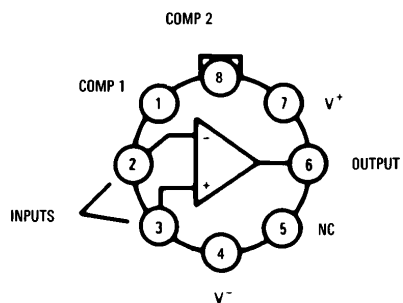

TL/H/7758-13

### Dual-In-Line Package

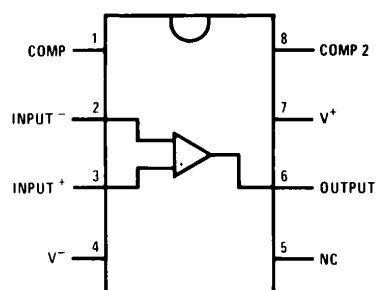

TL/H/7758-15

### Top View

Order Number LM108J-8/883, LM308M or LM308N  
See NS Package Number J08A, M08A or N08E

\*Package is connected to Pin 4 (V-)

\*\*Unused pin (no internal connection) to allow for input anti-leakage guard ring on printed circuit board layout.

Order Number LM108H, LM108H/883,  
LM308AH or LM308H  
See NS Package Number H08C

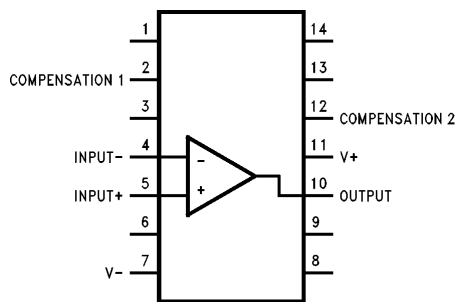

TL/H/7758-16

### Top View

Order Number LM108J/883  
See NS Package Number J14A

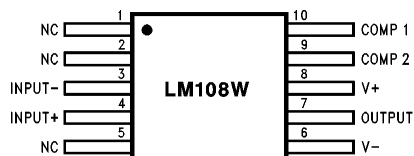

TL/H/7758-17

Order Number LM108W/883  
See NS Package Number W10A

†Also available per JM38510/10104

**Physical Dimensions** inches (millimeters)

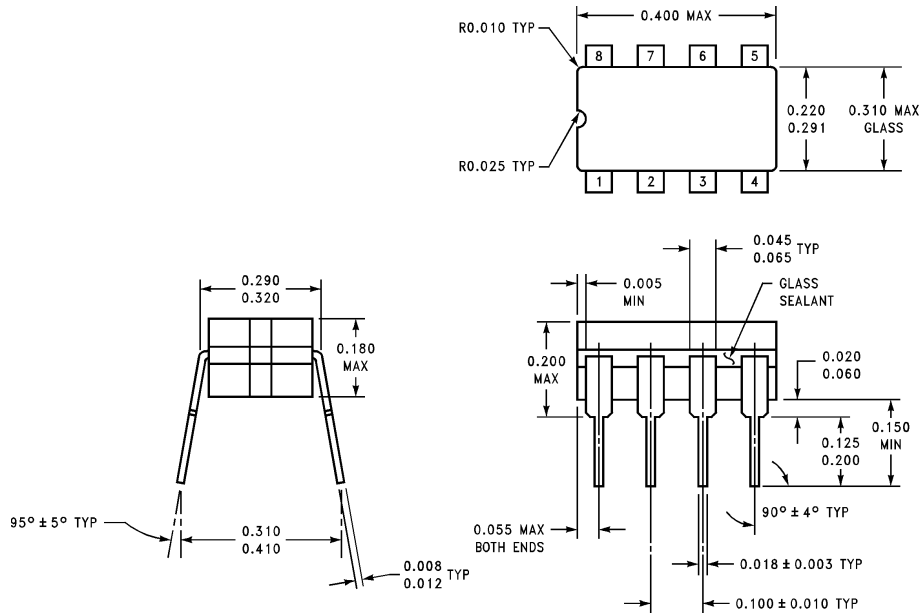

**Ceramic Dual-In-Line Package (J)**  
**Order Number LM108J/883**  
**NS Package Number J08A**

J08A (REV K)

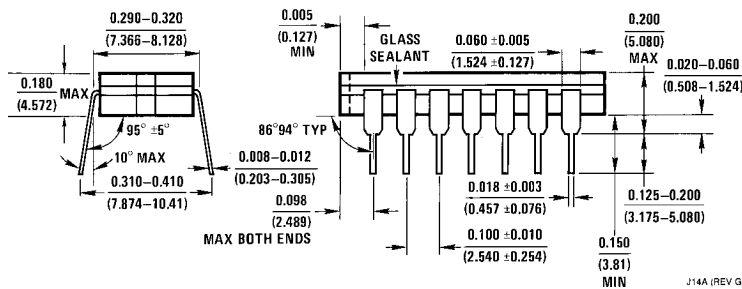
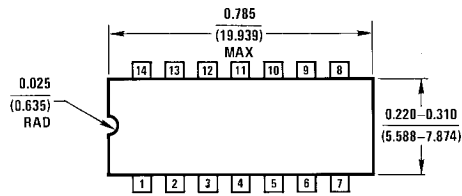

**Ceramic Dual-In-Line Package (J)**  
**Order Number LM108J/883**  
**NS Package Number J14A**

J14A (REV G)

**Physical Dimensions** inches (millimeters) (Continued)

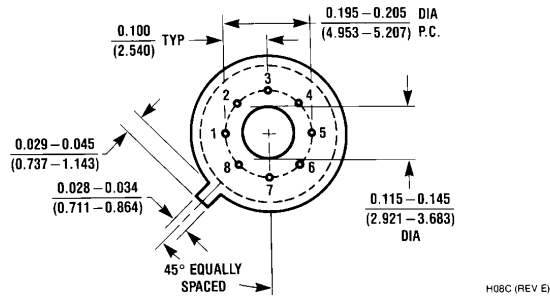
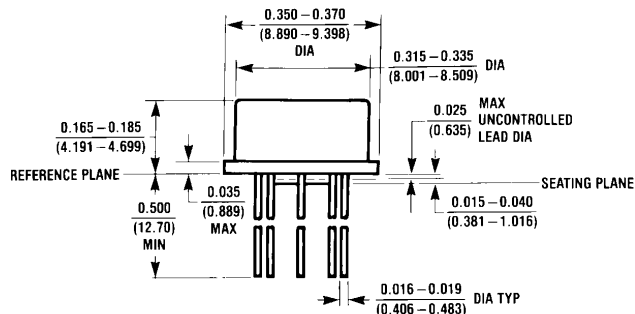

**Metal Can Package (H)**  
**Order Number LM108H, LM108H/883 or LM308H**  
**NS Package Number H08C**

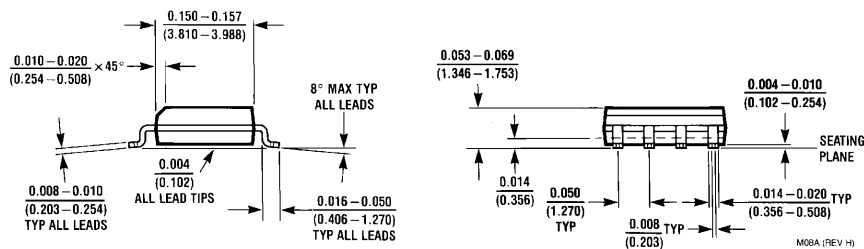
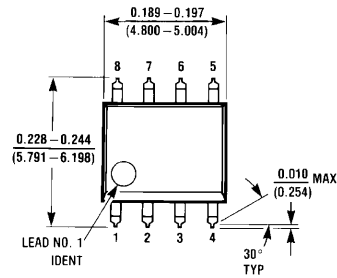

**S.O. Package (M)**  
**Order Number LM308M**  
**NS Package Number M08A**

Physical Dimensions inches (millimeters) (Continued)

Molded Dual-In-Line Package (N)  
 Order Number LM308N  
 NS Package Number N08E

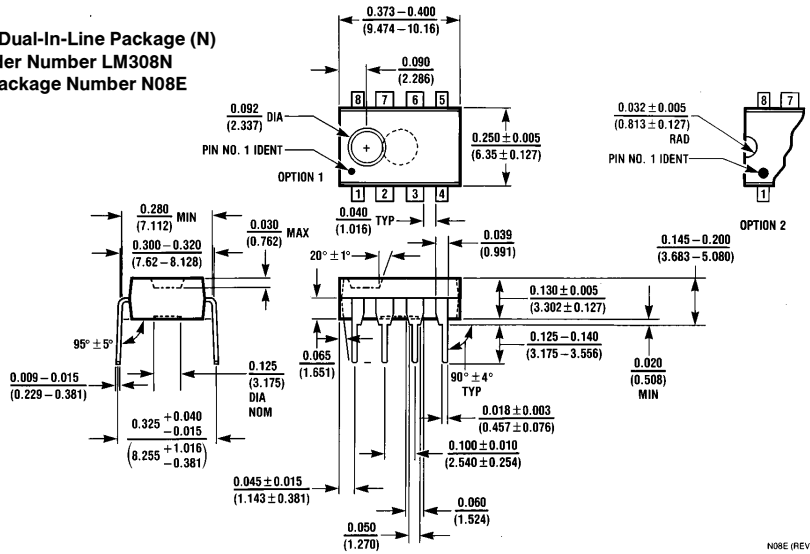

N08E (REV F)

Ceramic Flatpack Package (W)  
 Order Number LM108AW/883 or  
 LM108W/883  
 NS Package Number W10A

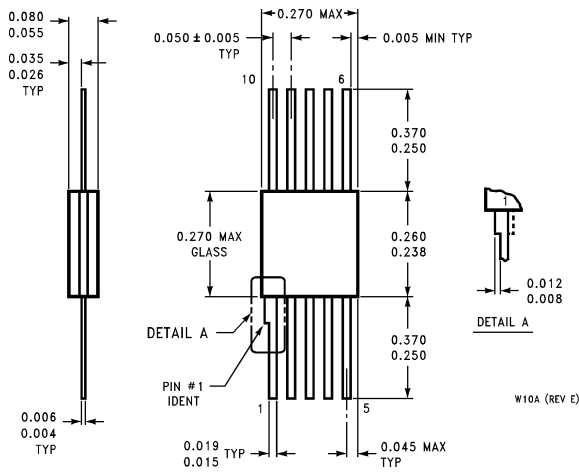

W10A (REV E)