

CMOS BCD-To-Decimal Decoder

Features

- High Voltage Type (20V Rating)
- BCD-to-Decimal Decoding or Binary-to-Octal Decoding
- High Decoded Output Drive Capability
- “Positive Logic” Inputs and Outputs - Decoded Outputs Go High On Selection
- Medium-Speed Operation
 - $t_{PHL}, t_{PLH} = 80\text{ns}$ (typ) at $V_{DD} = 10\text{V}$
- Standardized Symmetrical Output Characteristics
- 100% Tested For Quiescent Current at 20V
- Maximum Input Current of $1\mu\text{A}$ at 18V Over Full Package-Temperature Range;
 - 100nA at 18V and $+25^\circ\text{C}$
- Noise Margin (Over Full Package Temperature Range):
 - 1V at $V_{DD} = 5\text{V}$
 - 2V at $V_{DD} = 10\text{V}$
 - 2.5V at $V_{DD} = 15\text{V}$
- 5V, 10V and 15V Parametric Ratings
- Meets All Requirements of JEDEC Tentative Standard No. 13B, “Standard Specifications for Description of ‘B’ Series CMOS Devices”

Applications

- Code Conversion
- Indication-Tube Decoder
- Address Decoding - Memory Selection Control

Description

CD4028BMS types are BCD-to-decimal or binary-to-octal decoders consisting of buffering on all 4 inputs, decoding logic gates, and 10 output buffers. A BCD code applied to the four inputs, A to D, results in a high level at the selected one of 10 decimal decoded outputs. Similarly, a 3-bit binary code applied to inputs A through C is decoded in octal code at output 0 to 7 if D = “0”. High drive capability is provided at all outputs to enhance dc and dynamic performance in high fan-out applications.

The CD4028BMS is supplied in these 16-lead outline packages:

| | |
|------------------|-----|
| Braze Seal DIP | H4S |
| Frit Seal DIP | H1E |
| Ceramic Flatpack | H3X |

Pinout

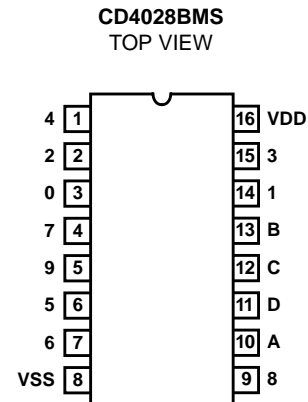

Functional Diagram

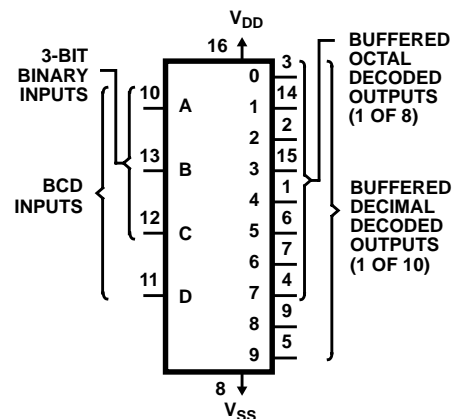

Specifications CD4028BMS

Absolute Maximum Ratings

DC Supply Voltage Range, (VDD) -0.5V to +20V
 (Voltage Referenced to VSS Terminals)
 Input Voltage Range, All Inputs -0.5V to VDD +0.5V
 DC Input Current, Any One Input ±10mA
 Operating Temperature Range -55°C to +125°C
 Package Types D, F, K, H
 Storage Temperature Range (TSTG) -65°C to +150°C
 Lead Temperature (During Soldering) +265°C
 At Distance 1/16 ± 1/32 Inch (1.59mm ± 0.79mm) from case for
 10s Maximum

Reliability Information

Thermal Resistance θ_{ja} θ_{jc}
 Ceramic DIP and FRIT Package 80°C/W 20°C/W
 Flatpack Package 70°C/W 20°C/W
 Maximum Package Power Dissipation (PD) at +125°C
 For TA = -55°C to +100°C (Package Type D, F, K) 500mW
 For TA = +100°C to +125°C (Package Type D, F, K) Derate
 Linearity at 12mW/°C to 200mW
 Device Dissipation per Output Transistor 100mW
 For TA = Full Package Temperature Range (All Package Types)
 Junction Temperature +175°C

TABLE 1. DC ELECTRICAL PERFORMANCE CHARACTERISTICS

| PARAMETER | SYMBOL | CONDITIONS (NOTE 1) | | GROUP A SUBGROUPS | TEMPERATURE | LIMITS | | UNITS |
|-----------------------------|--------|------------------------------------|-----------|-------------------|----------------------|-------------|-------------|-------|
| | | | | | | MIN | MAX | |
| Supply Current | IDD | VDD = 20V, VIN = VDD or GND | | 1 | +25°C | - | 10 | μA |
| | | | | 2 | +125°C | - | 1000 | μA |
| | | VDD = 18V, VIN = VDD or GND | | 3 | -55°C | - | 10 | μA |
| Input Leakage Current | IIL | VIN = VDD or GND | VDD = 20 | 1 | +25°C | -100 | - | nA |
| | | | VDD = 18V | 2 | +125°C | -1000 | - | nA |
| | | | | 3 | -55°C | -100 | - | nA |
| Input Leakage Current | IIH | VIN = VDD or GND | VDD = 20 | 1 | +25°C | - | 100 | nA |
| | | | VDD = 18V | 2 | +125°C | - | 1000 | nA |
| | | | | 3 | -55°C | - | 100 | nA |
| Output Voltage | VOL15 | VDD = 15V, No Load | | 1, 2, 3 | +25°C, +125°C, -55°C | - | 50 | mV |
| Output Voltage | VOH15 | VDD = 15V, No Load (Note 3) | | 1, 2, 3 | +25°C, +125°C, -55°C | 14.95 | - | V |
| Output Current (Sink) | IOL5 | VDD = 5V, VOUT = 0.4V | | 1 | +25°C | 0.53 | - | mA |
| Output Current (Sink) | IOL10 | VDD = 10V, VOUT = 0.5V | | 1 | +25°C | 1.4 | - | mA |
| Output Current (Sink) | IOL15 | VDD = 15V, VOUT = 1.5V | | 1 | +25°C | 3.5 | - | mA |
| Output Current (Source) | IOH5A | VDD = 5V, VOUT = 4.6V | | 1 | +25°C | - | -0.53 | mA |
| Output Current (Source) | IOH5B | VDD = 5V, VOUT = 2.5V | | 1 | +25°C | - | -1.8 | mA |
| Output Current (Source) | IOH10 | VDD = 10V, VOUT = 9.5V | | 1 | +25°C | - | -1.4 | mA |
| Output Current (Source) | IOH15 | VDD = 15V, VOUT = 13.5V | | 1 | +25°C | - | -3.5 | mA |
| N Threshold Voltage | VNTH | VDD = 10V, ISS = -10μA | | 1 | +25°C | -2.8 | -0.7 | V |
| P Threshold Voltage | VPTH | VSS = 0V, IDD = 10μA | | 1 | +25°C | 0.7 | 2.8 | V |
| Functional | F | VDD = 2.8V, VIN = VDD or GND | | 7 | +25°C | VOH > VDD/2 | VOL < VDD/2 | V |
| | | VDD = 20V, VIN = VDD or GND | | 7 | +25°C | | | |
| | | VDD = 18V, VIN = VDD or GND | | 8A | +125°C | | | |
| | | VDD = 3V, VIN = VDD or GND | | 8B | -55°C | | | |
| Input Voltage Low (Note 2) | VIL | VDD = 5V, VOH > 4.5V, VOL < 0.5V | | 1, 2, 3 | +25°C, +125°C, -55°C | - | 1.5 | V |
| Input Voltage High (Note 2) | VIH | VDD = 5V, VOH > 4.5V, VOL < 0.5V | | 1, 2, 3 | +25°C, +125°C, -55°C | 3.5 | - | V |
| Input Voltage Low (Note 2) | VIL | VDD = 15V, VOH > 13.5V, VOL < 1.5V | | 1, 2, 3 | +25°C, +125°C, -55°C | - | 4 | V |
| Input Voltage High (Note 2) | VIH | VDD = 15V, VOH > 13.5V, VOL < 1.5V | | 1, 2, 3 | +25°C, +125°C, -55°C | 11 | - | V |

NOTES: 1. All voltages referenced to device GND, 100% testing being implemented.
 2. Go/No Go test with limits applied to inputs.
 3. For accuracy, voltage is measured differentially to VDD. Limit is 0.050V max.

Specifications CD4028BMS

TABLE 2. AC ELECTRICAL PERFORMANCE CHARACTERISTICS

| PARAMETER | SYMBOL | CONDITIONS (NOTE 1, 2) | GROUP A SUBGROUPS | TEMPERATURE | LIMITS | | UNITS |
|-------------------|--------------|----------------------------|----------------------|---------------|--------|-----|-------|
| | | | | | MIN | MAX | |
| Propagation Delay | TPHL TPLH | VDD = 5V, VIN = VDD or GND | 9 | +25°C | - | 350 | ns |
| | | | 10, 11 | +125°C, -55°C | - | 473 | ns |
| Transition Time | TTHL TTLH | VDD = 5V, VIN = VDD or GND | 9 | +25°C | - | 200 | ns |
| | | | 10, 11 | +125°C, -55°C | - | 270 | ns |

NOTES:

1. CL = 50pF, RL = 200K, Input TR, TF < 20ns.
2. -55°C and +125°C limits guaranteed, 100% testing being implemented.

TABLE 3. ELECTRICAL PERFORMANCE CHARACTERISTICS

| PARAMETER | SYMBOL | CONDITIONS | NOTES | TEMPERATURE | LIMITS | | UNITS |
|-------------------------|--------|-------------------------------|-------|-------------------------|--------|-------|-------|
| | | | | | MIN | MAX | |
| Supply Current | IDD | VDD = 5V, VIN = VDD or GND | 1, 2 | -55°C, +25°C | - | 5 | μA |
| | | | | +125°C | - | 150 | μA |
| | | VDD = 10V, VIN = VDD or GND | 1, 2 | -55°C, +25°C | - | 10 | μA |
| | | | | +125°C | - | 300 | μA |
| | | VDD = 15V, VIN = VDD or GND | 1, 2 | -55°C, +25°C | - | 10 | μA |
| | | | | +125°C | - | 600 | μA |
| Output Voltage | VOL | VDD = 5V, No Load | 1, 2 | +25°C, +125°C, -55°C | - | 50 | mV |
| Output Voltage | VOL | VDD = 10V, No Load | 1, 2 | +25°C, +125°C, -55°C | - | 50 | mV |
| Output Voltage | VOH | VDD = 5V, No Load | 1, 2 | +25°C, +125°C, -55°C | 4.95 | - | V |
| Output Voltage | VOH | VDD = 10V, No Load | 1, 2 | +25°C, +125°C, -55°C | 9.95 | - | V |
| Output Current (Sink) | IOL5 | VDD = 5V, VOUT = 0.4V | 1, 2 | +125°C | 0.36 | - | mA |
| | | | | -55°C | 0.64 | - | mA |
| Output Current (Sink) | IOL10 | VDD = 10V, VOUT = 0.5V | 1, 2 | +125°C | 0.9 | - | mA |
| | | | | -55°C | 1.6 | - | mA |
| Output Current (Sink) | IOL15 | VDD = 15V, VOUT = 1.5V | 1, 2 | +125°C | 2.4 | - | mA |
| | | | | -55°C | 4.2 | - | mA |
| Output Current (Source) | IOH5A | VDD = 5V, VOUT = 4.6V | 1, 2 | +125°C | - | -0.36 | mA |
| | | | | -55°C | - | -0.64 | mA |
| Output Current (Source) | IOH5B | VDD = 5V, VOUT = 2.5V | 1, 2 | +125°C | - | -1.15 | mA |
| | | | | -55°C | - | -2.0 | mA |
| Output Current (Source) | IOH10 | VDD = 10V, VOUT = 9.5V | 1, 2 | +125°C | - | -0.9 | mA |
| | | | | -55°C | - | -1.6 | mA |
| Output Current (Source) | IOH15 | VDD = 15V, VOUT = 13.5V | 1, 2 | +125°C | - | -2.4 | mA |
| | | | | -55°C | - | -4.2 | mA |
| Input Voltage Low | VIL | VDD = 10V, VOH > 9V, VOL < 1V | 1, 2 | +25°C, +125°C, -55°C | - | 3 | V |
| Input Voltage High | VIH | VDD = 10V, VOH > 9V, VOL < 1V | 1, 2 | +25°C, +125°C, -55°C | 7 | - | V |

Specifications CD4028BMS

TABLE 3. ELECTRICAL PERFORMANCE CHARACTERISTICS (Continued)

| PARAMETER | SYMBOL | CONDITIONS | NOTES | TEMPERATURE | LIMITS | | UNITS |
|-------------------|--------------|------------|---------|-------------|--------|-----|-------|
| | | | | | MIN | MAX | |
| Propagation Delay | TPHL TPLH | VDD = 10V | 1, 2, 3 | +25°C | - | 160 | ns |
| | | VDD = 15V | 1, 2, 3 | +25°C | - | 120 | ns |
| Transition Time | TTHL TTLH | VDD = 10V | 1, 2, 3 | +25°C | - | 100 | ns |
| | | VDD = 15V | 1, 2, 3 | +25°C | - | 80 | ns |
| Input Capacitance | CIN | | 1, 2 | +25°C | - | 7.5 | pF |

NOTES:

1. All voltages referenced to device GND.
2. The parameters listed on Table 3 are controlled via design or process and are not directly tested. These parameters are characterized on initial design release and upon design changes which would affect these characteristics.
3. CL = 50pF, RL = 200K, Input TR, TF < 20ns.

TABLE 4. POST IRRADIATION ELECTRICAL PERFORMANCE CHARACTERISTICS

| PARAMETER | SYMBOL | CONDITIONS | NOTES | TEMPERATURE | LIMITS | | UNITS |
|---------------------------|--------------|-----------------------------|------------|-------------|-------------|--------------------|-------|
| | | | | | MIN | MAX | |
| Supply Current | IDD | VDD = 20V, VIN = VDD or GND | 1, 4 | +25°C | - | 25 | μA |
| N Threshold Voltage | VNTH | VDD = 10V, ISS = -10μA | 1, 4 | +25°C | -2.8 | -0.2 | V |
| N Threshold Voltage Delta | ΔVTN | VDD = 10V, ISS = -10μA | 1, 4 | +25°C | - | ±1 | V |
| P Threshold Voltage | VTP | VSS = 0V, IDD = 10μA | 1, 4 | +25°C | 0.2 | 2.8 | V |
| P Threshold Voltage Delta | ΔVTP | VSS = 0V, IDD = 10μA | 1, 4 | +25°C | - | ±1 | V |
| Functional | F | VDD = 18V, VIN = VDD or GND | 1 | +25°C | VOH > VDD/2 | VOL < VDD/2 | V |
| | | VDD = 3V, VIN = VDD or GND | | | | | |
| Propagation Delay Time | TPHL TPLH | VDD = 5V | 1, 2, 3, 4 | +25°C | - | 1.35 x +25°C Limit | ns |

- NOTES: 1. All voltages referenced to device GND. 2. CL = 50pF, RL = 200K, Input TR, TF < 20ns. 3. See Table 2 for +25°C limit. 4. Read and Record

TABLE 5. BURN-IN AND LIFE TEST DELTA PARAMETERS +25°C

| PARAMETER | SYMBOL | DELTA LIMIT |
|-------------------------|--------|--------------------------|
| Supply Current - MSI-2 | IDD | ± 1.0μA |
| Output Current (Sink) | IOL5 | ± 20% x Pre-Test Reading |
| Output Current (Source) | IOH5A | ± 20% x Pre-Test Reading |

TABLE 6. APPLICABLE SUBGROUPS

| CONFORMANCE GROUP | MIL-STD-883 METHOD | GROUP A SUBGROUPS | READ AND RECORD |
|-------------------------------|--------------------|-------------------|------------------|
| Initial Test (Pre Burn-In) | 100% 5004 | 1, 7, 9 | IDD, IOL5, IOH5A |
| Interim Test 1 (Post Burn-In) | 100% 5004 | 1, 7, 9 | IDD, IOL5, IOH5A |
| Interim Test 2 (Post Burn-In) | 100% 5004 | 1, 7, 9 | IDD, IOL5, IOH5A |
| PDA (Note 1) | 100% 5004 | 1, 7, 9, Deltas | |
| Interim Test 3 (Post Burn-In) | 100% 5004 | 1, 7, 9 | IDD, IOL5, IOH5A |
| PDA (Note 1) | 100% 5004 | 1, 7, 9, Deltas | |

Specifications CD4028BMS

TABLE 6. APPLICABLE SUBGROUPS (Continued)

| CONFORMANCE GROUP | | MIL-STD-883 METHOD | GROUP A SUBGROUPS | READ AND RECORD |
|-------------------|--------------|--------------------|---------------------------------------|------------------------------|
| Final Test | | 100% 5004 | 2, 3, 8A, 8B, 10, 11 | |
| Group A | | Sample 5005 | 1, 2, 3, 7, 8A, 8B, 9, 10, 11 | |
| Group B | Subgroup B-5 | Sample 5005 | 1, 2, 3, 7, 8A, 8B, 9, 10, 11, Deltas | Subgroups 1, 2, 3, 9, 10, 11 |
| | Subgroup B-6 | Sample 5005 | 1, 7, 9 | |
| Group D | | Sample 5005 | 1, 2, 3, 8A, 8B, 9 | Subgroups 1, 2 3 |

NOTE: 1. 5% Parametric, 3% Functional; Cumulative for Static 1 and 2.

TABLE 7. TOTAL DOSE IRRADIATION

| CONFORMANCE GROUPS | MIL-STD-883 METHOD | TEST | | READ AND RECORD | |
|--------------------|--------------------|-----------|------------|-----------------|------------|
| | | PRE-IRRAD | POST-IRRAD | PRE-IRRAD | POST-IRRAD |
| Group E Subgroup 2 | 5005 | 1, 7, 9 | Table 4 | 1, 9 | Table 4 |

TABLE 8. BURN-IN AND IRRADIATION TEST CONNECTIONS

| FUNCTION | OPEN | GROUND | VDD | 9V ± -0.5V | OSCILLATOR | |
|----------------------------|------------------|------------|-------------|------------------|------------|-------|
| | | | | | 50kHz | 25kHz |
| Static Burn-In 1 Note 1 | 1 - 7, 9, 14, 15 | 8, 10 - 13 | 16 | | | |
| Static Burn-In 2 Note 1 | 1 - 7, 9, 14, 15 | 8 | 10 - 13, 16 | | | |
| Dynamic Burn-In Note 1 | - | 8 | 16 | 1 - 7, 9, 14, 15 | 10, 12, 13 | 11 |
| Irradiation Note 2 | 1 - 7, 9, 14, 15 | 8 | 10 - 13, 16 | | | |

NOTE:

1. Each pin except VDD and GND will have a series resistor of 10K ± 5%, VDD = 18V ± 0.5V
2. Each pin except VDD and GND will have a series resistor of 47K ± 5%; Group E, Subgroup 2, sample size is 4 dice/wafer, 0 failures, VDD = 10V ± 0.5V

CD4028BMS

Logic Diagram

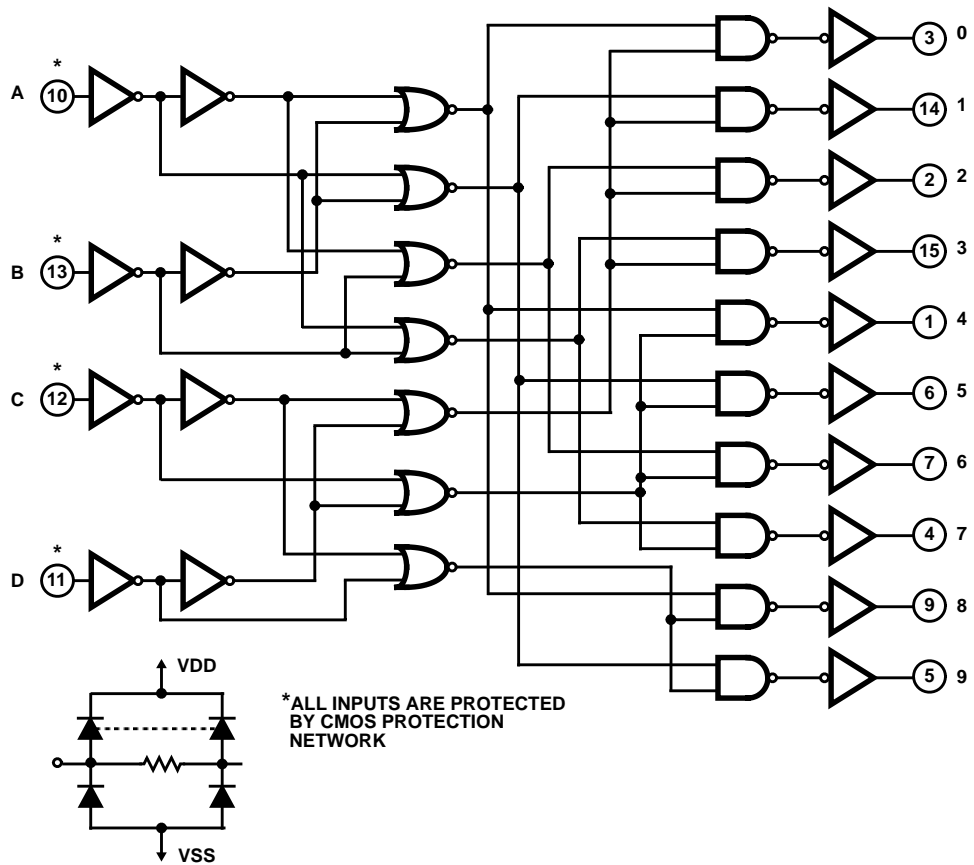

TABLE 1. TRUTH TABLE

| D | C | B | A | 0 | 1 | 2 | 3 | 4 | 5 | 6 | 7 | 8 | 9 |
|---|---|---|---|---|---|---|---|---|---|---|---|---|---|
| 0 | 0 | 0 | 0 | 1 | 0 | 0 | 0 | 0 | 0 | 0 | 0 | 0 | 0 |
| 0 | 0 | 0 | 1 | 0 | 1 | 0 | 0 | 0 | 0 | 0 | 0 | 0 | 0 |
| 0 | 0 | 1 | 0 | 0 | 0 | 1 | 0 | 0 | 0 | 0 | 0 | 0 | 0 |
| 0 | 0 | 1 | 1 | 0 | 0 | 0 | 1 | 0 | 0 | 0 | 0 | 0 | 0 |
| 0 | 1 | 0 | 0 | 0 | 0 | 0 | 0 | 1 | 0 | 0 | 0 | 0 | 0 |
| 0 | 1 | 0 | 1 | 0 | 0 | 0 | 0 | 0 | 1 | 0 | 0 | 0 | 0 |
| 0 | 1 | 1 | 0 | 0 | 0 | 0 | 0 | 0 | 0 | 1 | 0 | 0 | 0 |
| 0 | 1 | 1 | 1 | 0 | 0 | 0 | 0 | 0 | 0 | 0 | 1 | 0 | 0 |
| 1 | 0 | 0 | 0 | 0 | 0 | 0 | 0 | 0 | 0 | 0 | 0 | 1 | 0 |
| 1 | 0 | 0 | 1 | 0 | 0 | 0 | 0 | 0 | 0 | 0 | 0 | 0 | 1 |
| 1 | 0 | 1 | 0 | 0 | 0 | 0 | 0 | 0 | 0 | 0 | 0 | 0 | 0 |
| 1 | 0 | 1 | 1 | 0 | 0 | 0 | 0 | 0 | 0 | 0 | 0 | 0 | 0 |
| 1 | 1 | 0 | 0 | 0 | 0 | 0 | 0 | 0 | 0 | 0 | 0 | 0 | 0 |
| 1 | 1 | 0 | 1 | 0 | 0 | 0 | 0 | 0 | 0 | 0 | 0 | 0 | 0 |
| 1 | 1 | 1 | 0 | 0 | 0 | 0 | 0 | 0 | 0 | 0 | 0 | 0 | 0 |
| 1 | 1 | 1 | 1 | 0 | 0 | 0 | 0 | 0 | 0 | 0 | 0 | 0 | 0 |

1 = HIGH LEVEL

0 = LOW LEVEL

Typical Performance Characteristics

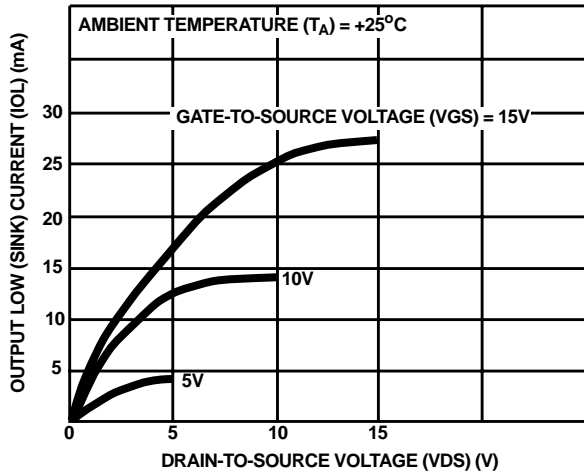

FIGURE 1. TYPICAL OUTPUT LOW (SINK) CURRENT CAPACITANCE

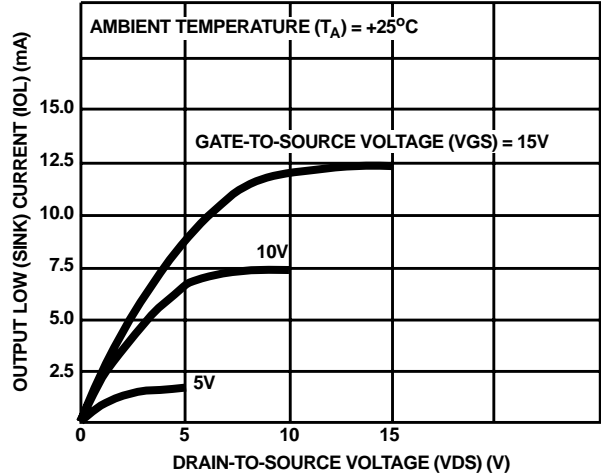

FIGURE 2. MINIMUM OUTPUT LOW (SINK) CURRENT CAPACITANCE

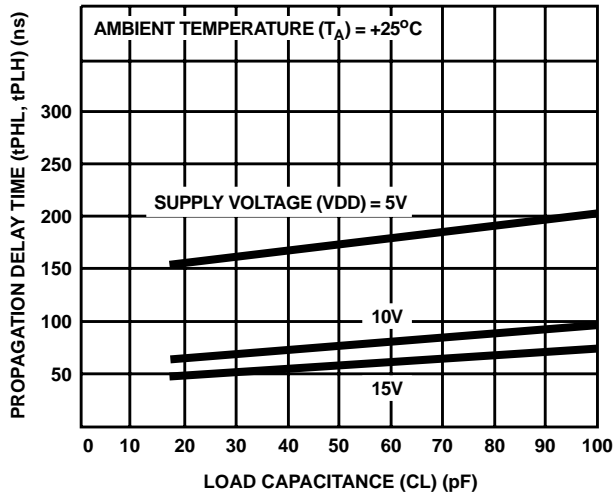

FIGURE 3. TYPICAL PROPAGATION DELAY TIME AS A FUNCTION OF LOAD CAPACITANCE

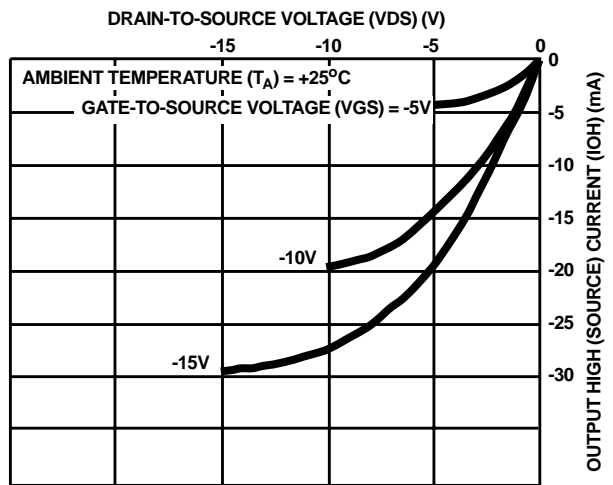

FIGURE 4. TYPICAL OUTPUT HIGH (SOURCE) CURRENT CHARACTERISTICS

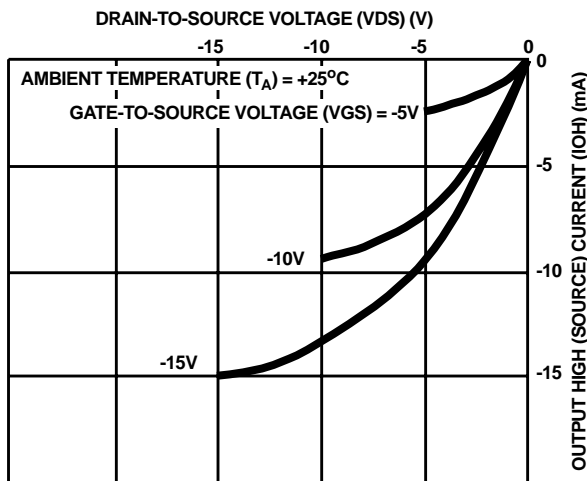

FIGURE 5. MINIMUM OUTPUT HIGH (SOURCE) CURRENT CHARACTERISTICS

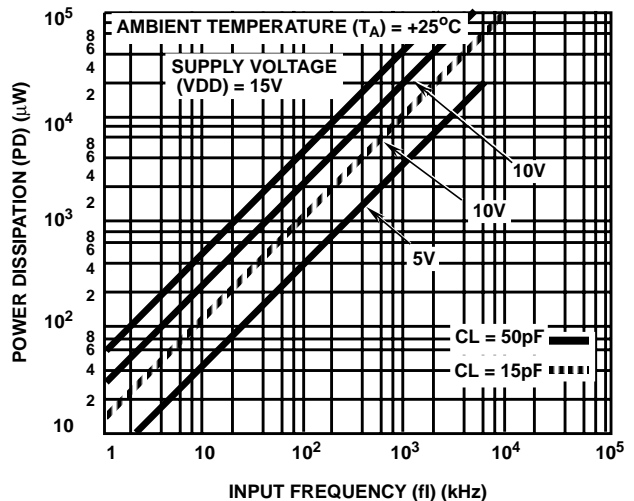

FIGURE 6. TYPICAL DYNAMIC POWER DISSIPATION AS A FUNCTION OF INPUT FREQUENCY

CD4028BMS

Typical Performance Characteristics (Continued)

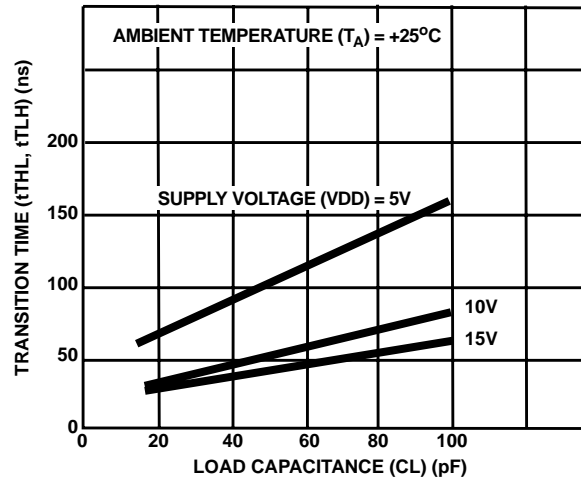

FIGURE 7. TYPICAL TRANSITION TIME AS A FUNCTION OF LOAD CAPACITANCE

Typical Applications

The circuit shown in Figure 8 converts any 4-bit code to a decimal or hexadecimal code. Table 2 shows a number of codes and the decimal or hexadecimal number in these codes which must be applied to the input terminals of the CD4028BMS to select a particular output. For example: in order to get a high on output number 8 the input must be either an 8 expressed in 4-bit Binary code, a 15 expressed in 4-bit Gray code, or a 5 expressed in Excess-3 code.

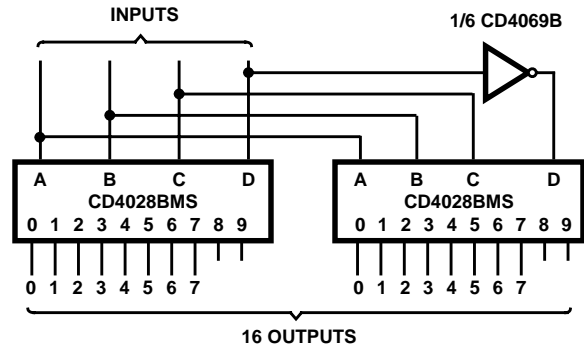

FIGURE 8. CODE CONVERSION CIRCUIT

TABLE 2. CODE CONVERSION CHART

| INPUTS | | | | INPUT CODES | | | | OUTPUT NUMBER | | | | | | | | | | | | | | | | | |
|--------|---|---|---|--------------|------------|----------|---------------|---------------|---------|---|---|---|---|---|---|---|---|---|---|----|----|----|----|----|----|
| | | | | HEXA-DECIMAL | | DECIMAL | | | | | | | | | | | | | | | | | | | |
| D | C | B | A | 4-BIT BINARY | 4-BIT GRAY | EXCESS-3 | EXCESS-3 GRAY | AIKEN | 4-2-2-1 | 0 | 1 | 2 | 3 | 4 | 5 | 6 | 7 | 8 | 9 | 10 | 11 | 12 | 13 | 14 | 15 |
| 0 | 0 | 0 | 0 | 0 | 0 | | | 0 | 0 | 1 | 0 | 0 | 0 | 0 | 0 | 0 | 0 | 0 | 0 | 0 | 0 | 0 | 0 | 0 | 0 |
| 0 | 0 | 0 | 1 | 1 | 1 | | | 1 | 1 | 0 | 1 | 0 | 0 | 0 | 0 | 0 | 0 | 0 | 0 | 0 | 0 | 0 | 0 | 0 | 0 |
| 0 | 0 | 1 | 0 | 2 | 3 | | 0 | 2 | 2 | 0 | 0 | 1 | 0 | 0 | 0 | 0 | 0 | 0 | 0 | 0 | 0 | 0 | 0 | 0 | 0 |
| 0 | 0 | 1 | 1 | 3 | 2 | 0 | 3 | 3 | | 0 | 0 | 0 | 1 | 0 | 0 | 0 | 0 | 0 | 0 | 0 | 0 | 0 | 0 | 0 | 0 |
| 0 | 1 | 0 | 0 | 4 | 7 | 1 | 4 | 4 | | 0 | 0 | 0 | 0 | 1 | 0 | 0 | 0 | 0 | 0 | 0 | 0 | 0 | 0 | 0 | 0 |
| 0 | 1 | 0 | 1 | 5 | 6 | 2 | | | 3 | 0 | 0 | 0 | 0 | 0 | 1 | 0 | 0 | 0 | 0 | 0 | 0 | 0 | 0 | 0 | 0 |
| 0 | 1 | 1 | 0 | 6 | 4 | 3 | 1 | | 4 | 0 | 0 | 0 | 0 | 0 | 0 | 1 | 0 | 0 | 0 | 0 | 0 | 0 | 0 | 0 | 0 |
| 0 | 1 | 1 | 1 | 7 | 5 | 4 | 2 | | | 0 | 0 | 0 | 0 | 0 | 0 | 0 | 1 | 0 | 0 | 0 | 0 | 0 | 0 | 0 | 0 |
| 1 | 0 | 0 | 0 | 8 | 15 | 5 | | | | 0 | 0 | 0 | 0 | 0 | 0 | 0 | 0 | 1 | 0 | 0 | 0 | 0 | 0 | 0 | 0 |
| 1 | 0 | 0 | 1 | 9 | 14 | 6 | | | 5 | 0 | 0 | 0 | 0 | 0 | 0 | 0 | 0 | 0 | 1 | 0 | 0 | 0 | 0 | 0 | 0 |
| 1 | 0 | 1 | 0 | 10 | 12 | 7 | 9 | | 6 | 0 | 0 | 0 | 0 | 0 | 0 | 0 | 0 | 0 | 0 | 1 | 0 | 0 | 0 | 0 | 0 |

CD4028BMS

TABLE 2. CODE CONVERSION CHART (Continued)

| INPUTS | | | | INPUT CODES | | | | OUTPUT NUMBER | | | | | | | | | | | | | | | | | |
|--------|---|---|---|--------------|------------|----------|---------------|---------------|---------|---|---|---|---|---|---|---|---|---|---|----|----|----|----|----|----|
| | | | | HEXA-DECIMAL | | DECIMAL | | | | | | | | | | | | | | | | | | | |
| D | C | B | A | 4-BIT BINARY | 4-BIT GRAY | EXCESS-3 | EXCESS-3 GRAY | AIKEN | 4-2-2-1 | 0 | 1 | 2 | 3 | 4 | 5 | 6 | 7 | 8 | 9 | 10 | 11 | 12 | 13 | 14 | 15 |
| 1 | 0 | 1 | 1 | 11 | 13 | 8 | | 5 | | 0 | 0 | 0 | 0 | 0 | 0 | 0 | 0 | 0 | 0 | 0 | 1 | 0 | 0 | 0 | 0 |
| 1 | 1 | 0 | 0 | 12 | 8 | 9 | 5 | 6 | | 0 | 0 | 0 | 0 | 0 | 0 | 0 | 0 | 0 | 0 | 0 | 0 | 1 | 0 | 0 | 0 |
| 1 | 1 | 0 | 1 | 13 | 9 | | 6 | 7 | 7 | 0 | 0 | 0 | 0 | 0 | 0 | 0 | 0 | 0 | 0 | 0 | 0 | 1 | 0 | 0 | 0 |
| 1 | 1 | 1 | 0 | 14 | 11 | | 8 | 8 | 8 | 0 | 0 | 0 | 0 | 0 | 0 | 0 | 0 | 0 | 0 | 0 | 0 | 0 | 1 | 0 | 0 |
| 1 | 1 | 1 | 1 | 15 | 10 | | 7 | 9 | 9 | 0 | 0 | 0 | 0 | 0 | 0 | 0 | 0 | 0 | 0 | 0 | 0 | 0 | 0 | 0 | 1 |

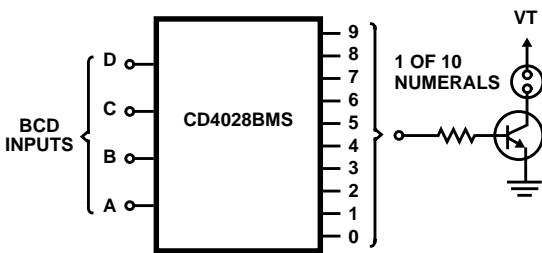

*(TRADEMARK) BURROUGHS CORP.

TUBE REQUIREMENTS

| TYPE | VT(Vdc) | NUMERAL mA/ |
|-----------------|---------|-------------|
| BURROUGHS B4081 | 170 | 14 |
| B4336/718 | 170 | 2 |
| B4032 | 170 | 14 |
| B4021 | 120 | 14 |

TRANSISTOR CHARACTERISTICS

Leakage with transistor cutoff $\leq 0.05\text{mA}$

$V(\text{BR})/\text{CEO} \geq 70\text{V}$

FIGURE 9. NEON READOUT (NIXIE TUBE*) DISPLAY APPLICATION

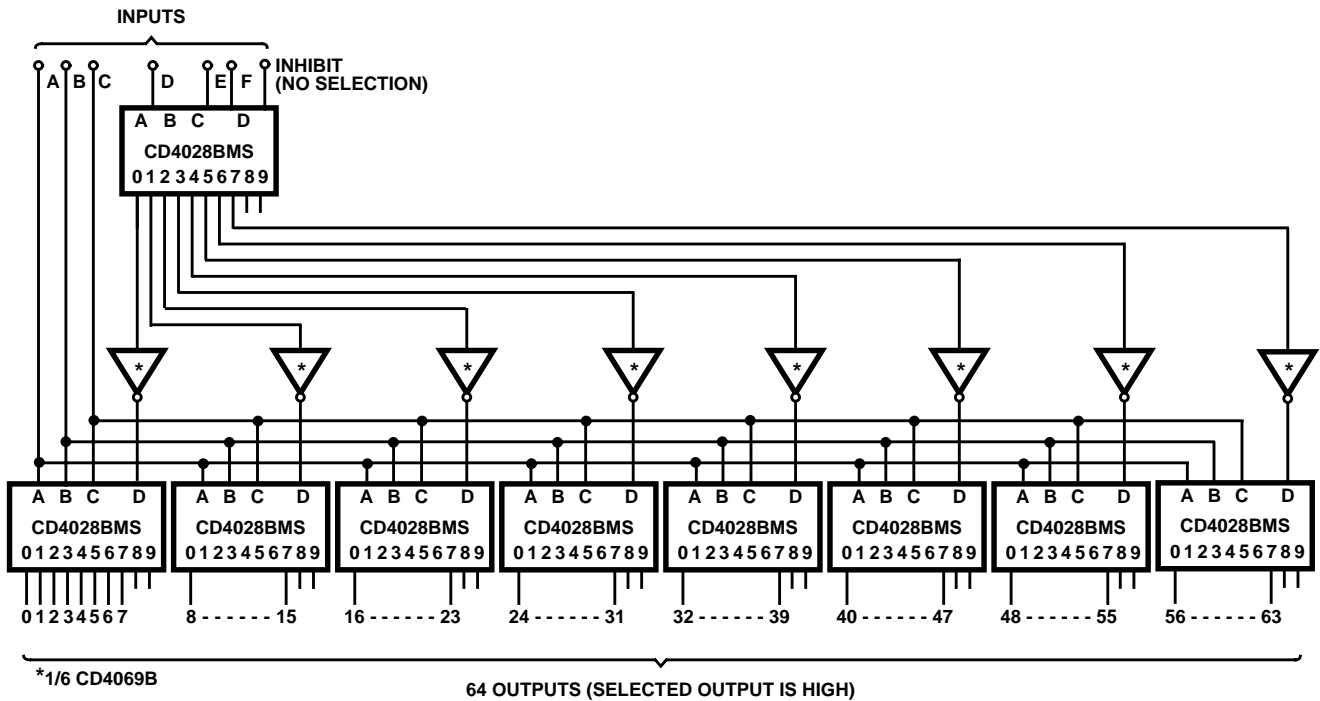
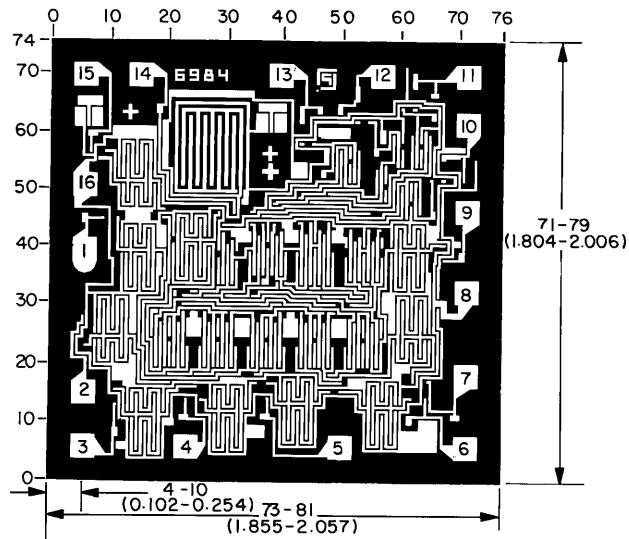

FIGURE 10. 6-BIT BINARY TO 1-OF-64 ADDRESS DECODER

CD4028BMS

Chip Dimensions and Pad Layout



Dimensions in parentheses are in millimeters and are derived from the basic inch dimensions as indicated. Grid graduations are in mils (10^{-3} inch)

METALLIZATION: Thickness: $11\text{k}\text{\AA} - 14\text{k}\text{\AA}$, AL.

PASSIVATION: $10.4\text{k}\text{\AA} - 15.6\text{k}\text{\AA}$, Silane

BOND PADS: 0.004 inches X 0.004 inches MIN

DIE THICKNESS: 0.0198 inches - 0.0218 inches