

DATA SHEET

For a complete data sheet, please also download:

- The IC06 74HC/HCT/HCU/HCMOS Logic Family Specifications
- The IC06 74HC/HCT/HCU/HCMOS Logic Package Information
- The IC06 74HC/HCT/HCU/HCMOS Logic Package Outlines

74HC/HCT195 4-bit parallel access shift register

Product specification
File under Integrated Circuits, IC06

December 1990

4-bit parallel access shift register

74HC/HCT195

FEATURES

- Asynchronous master reset
- J, \bar{K} , (D) inputs to the first stage
- Fully synchronous serial or parallel data transfer
- Shift right and parallel load capability
- Complement output from the last stage
- Output capability: standard
- I_{CC} category: MSI

GENERAL DESCRIPTION

The 74HC/HCT195 are high-speed Si-gate CMOS devices and are pin compatible with low power Schottky TTL (LSTTL). They are specified in compliance with JEDEC standard no. 7A.

The 74HC/HCT195 performs serial, parallel, serial-to-parallel or parallel-to-serial data transfer at very high speeds. The "195" operates on two primary modes: shift right ($Q_0 \rightarrow Q_1$) and parallel load, which are controlled

by the state of the parallel load enable (\overline{PE}) input. Serial data enters the first flip-flop (Q_0) via the J and \bar{K} inputs when the \overline{PE} input is HIGH and shifted one bit in the direction $Q_0 \rightarrow Q_1 \rightarrow Q_2 \rightarrow Q_3$ following each LOW-to-HIGH clock transition. The J and \bar{K} inputs provide the flexibility of the JK type input for special applications and by tying the pins together, the simple D-type input for general applications. The "195" appears as four common clocked D flip-flops when the \overline{PE} input is LOW.

After the LOW-to-HIGH clock transition, data on the parallel inputs (D_0 to D_3) is transferred to the respective Q_0 to Q_3 outputs. Shift left operation ($Q_3 \rightarrow Q_2$) can be achieved by tying the Q_n outputs to the D_{n-1} inputs and holding the \overline{PE} input LOW.

All parallel and serial data transfers are synchronous, occurring after each LOW-to-HIGH clock transition. There is no restriction on the activity of the J, \bar{K} , D_n and \overline{PE} inputs for logic operation other than the set-up and hold time requirements. A LOW on the asynchronous master reset (\overline{MR}) input sets all Q outputs LOW, independent of any other input condition.

QUICK REFERENCE DATA

GND = 0 V; T_{amb} = 25 °C; t_r = t_f = 6 ns

SYMBOL	PARAMETER	CONDITIONS	TYPICAL		UNIT
			HC	HCT	
t _{PHL} / t _{PLH}	propagation delay CP to Q _n	C _L = 15 pF; V _{CC} = 5 V	15	15	ns
f _{max}	maximum clock frequency		57	57	MHz
C _I	input capacitance		3.5	3.5	pF
C _{PD}	power dissipation capacitance per package	notes 1 and 2	105	105	pF

Notes

1. C_{PD} is used to determine the dynamic power dissipation (P_D in μW):

$$P_D = C_{PD} \times V_{CC}^2 \times f_i + \sum (C_L \times V_{CC}^2 \times f_o)$$
 where:
 - f_i = input frequency in MHz
 - f_o = output frequency in MHz
 - $\sum (C_L \times V_{CC}^2 \times f_o)$ = sum of outputs
 - C_L = output load capacitance in pF
 - V_{CC} = supply voltage in V
2. For HC the condition is V_I = GND to V_{CC}
For HCT the condition is V_I = GND to V_{CC} - 1,5 V

ORDERING INFORMATION

See "74HC/HCT/HCU/HCMOS Logic Package Information".

4-bit parallel access shift register

74HC/HCT195

PIN DESCRIPTION

PIN NO.	SYMBOL	NAME AND FUNCTION
1	\overline{MR}	master reset input (active LOW)
2	J	first stage J-input (active HIGH)
3	\overline{K}	first stage \overline{K} -input (active LOW)
4, 5, 6, 7	D ₀ to D ₃	parallel data inputs
8	GND	ground (0 V)
9	\overline{PE}	parallel enable input (active LOW)
10	CP	clock input (LOW-to-HIGH edge-triggered)
11	\overline{Q}_3	inverted output from the last stage
15, 14, 13, 12	Q ₀ to Q ₃	parallel outputs
16	V _{CC}	positive supply voltage

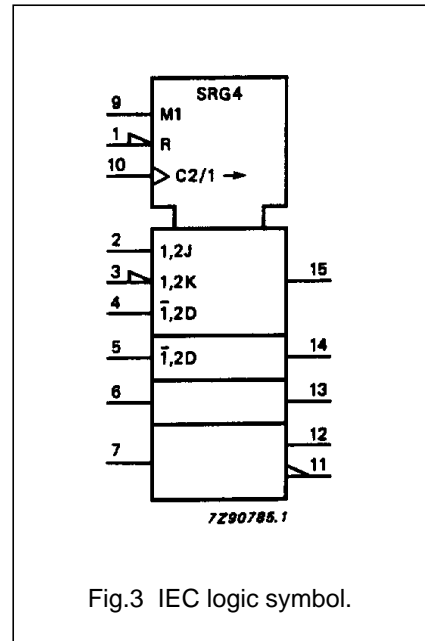
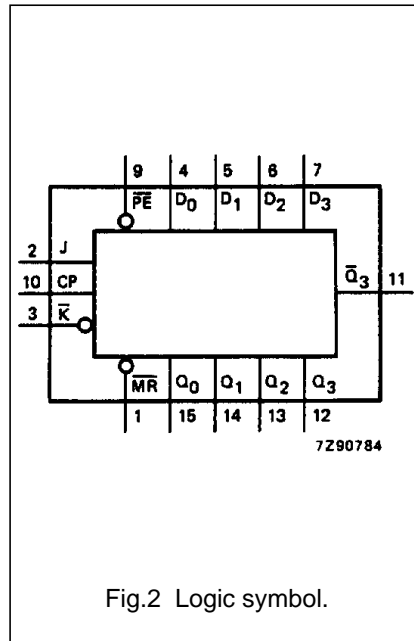
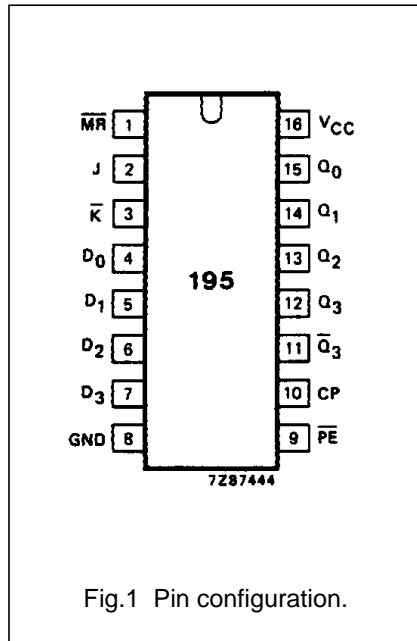

4-bit parallel access shift register

74HC/HCT195

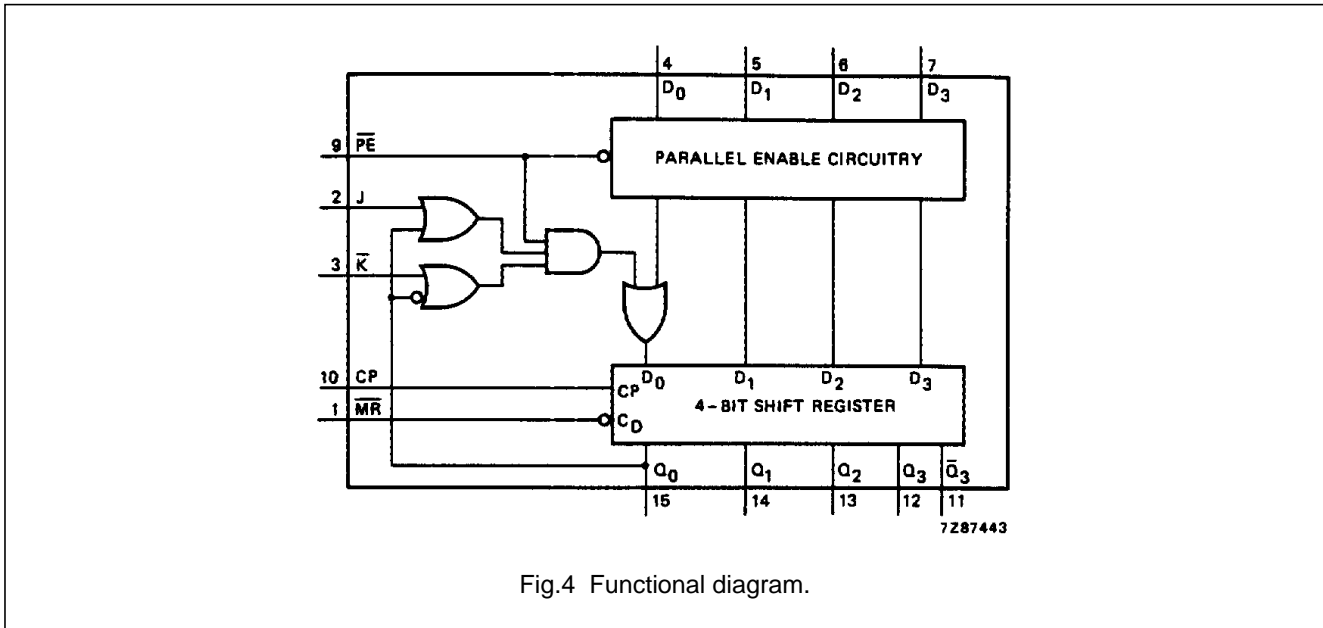

Fig.4 Functional diagram.

APPLICATIONS

- Serial data transfer
- Parallel data transfer
- Serial-to-parallel data transfer
- Parallel-to-serial data transfer

FUNCTION TABLE

OPERATING MODES	INPUTS						OUTPUTS				
	\overline{MR}	CP	\overline{PE}	J	\overline{K}	D_n	Q_0	Q_1	Q_2	Q_3	$\overline{Q_3}$
asynchronous reset	L	X	X	X	X	X	L	L	L	L	H
shift, set first stage	H	↑	h	h	h	X	H	q0	q1	q2	$\overline{q_2}$
shift, reset first stage	H	↑	h	l	l	X	\overline{L}	q0	q1	q2	$\overline{q_2}$
shift, toggle first stage	H	↑	h	h	l	X	$\overline{q_0}$	q0	q1	q2	$\overline{q_2}$
shift, retain first stage	H	↑	h	l	h	X	q0	q0	q1	q2	$\overline{q_2}$
parallel load	H	↑	l	X	X	d_n	d_0	d_1	d_2	d_3	$\overline{d_3}$

Notes

- H = HIGH voltage level
 h = HIGH voltage level one set-up time prior to the LOW-to-HIGH clock transition
 L = LOW voltage level
 l = LOW voltage level one set-up time prior to the LOW-to-HIGH clock transition
 q, d = lower case letters indicate the state of the referenced input (or output) one set-up time prior to the LOW-to-HIGH clock transition
 X = don't care
 ↑ = LOW-to-HIGH clock transition

4-bit parallel access shift register

74HC/HCT195

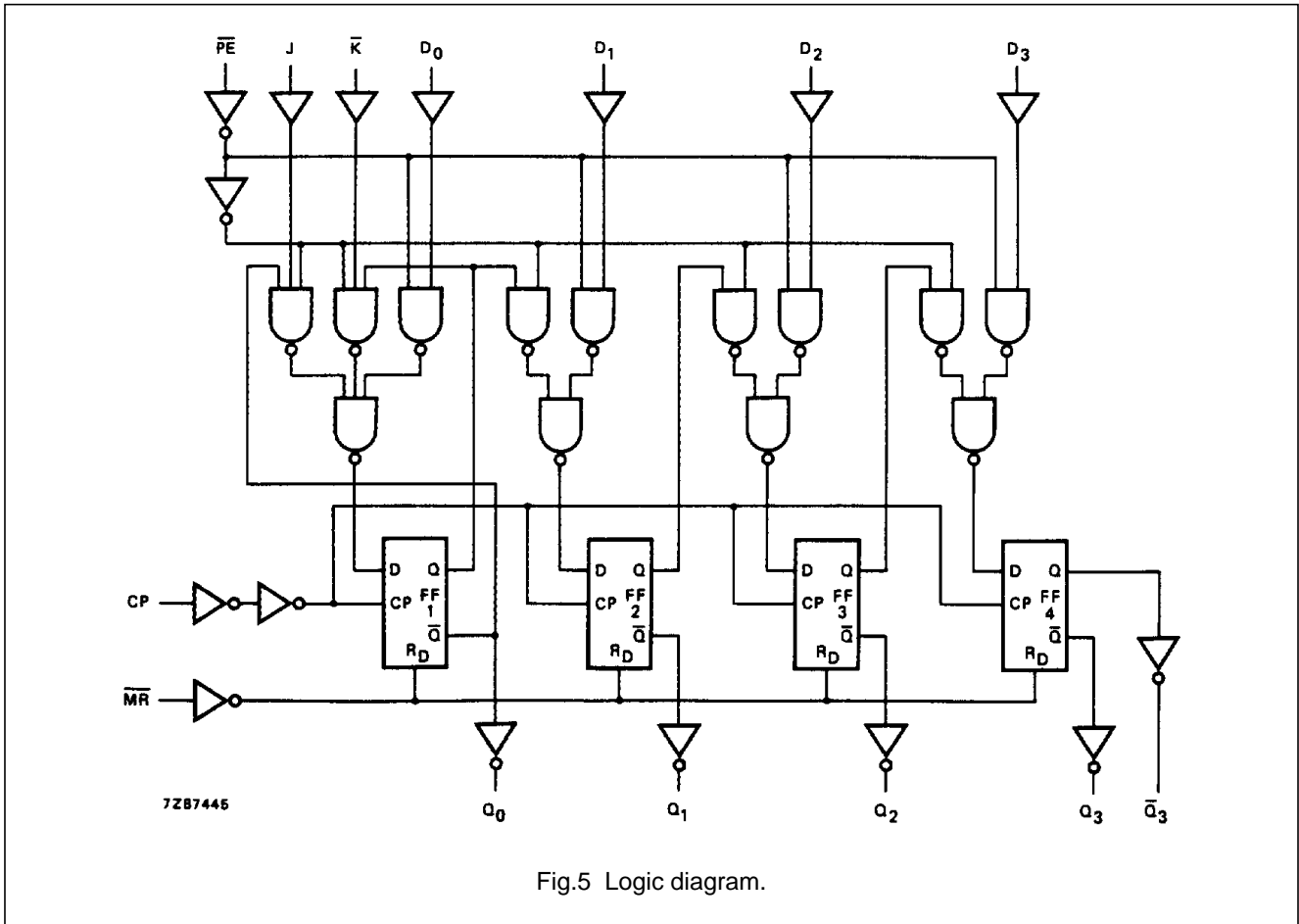

4-bit parallel access shift register

74HC/HCT195

DC CHARACTERISTICS FOR 74HC

For the DC characteristics see *"74HC/HCT/HCU/HCMOS Logic Family Specifications"*.

Output capability: standard

I_{CC} category: MSI

AC CHARACTERISTICS FOR 74HC

GND = 0 V; t_r = t_f = 6 ns; C_L = 50 pF

SYMBOL	PARAMETER	T _{amb} (°C)						UNIT	TEST CONDITIONS		
		74HC							V _{CC} (V)	WAVEFORMS	
		+25			-40 to +85		-40 to +125				
		min.	typ.	max.	min.	max.	min.				max.
t _{PHL} / t _{PLH}	propagation delay CP to Q _n		50 18 14	150 30 26		190 38 33		225 45 38	ns	2.0 4.5 6.0	Fig.6
t _{PHL}	propagation delay MR to Q _n		41 15 12	150 30 26		190 38 33		225 45 38	ns	2.0 4.5 6.0	Fig.8
t _{THL} / t _{TLH}	output transition time		19 7 6	75 15 13		95 19 16		110 22 19	ns	2.0 4.5 6.0	Fig.6
t _w	clock pulse width HIGH or LOW	80 16 14	17 6 5		100 20 17		120 24 20		ns	2.0 4.5 6.0	Fig.6
t _w	master reset pulse width LOW	80 16 14	11 4 3		100 20 17		120 24 20		ns	2.0 4.5 6.0	Fig.8
t _{rem}	removal time MR to CP	80 16 14	17 6 5		100 20 17		120 24 20		ns	2.0 4.5 6.0	Fig.8
t _{su}	set-up time J to CP	100 20 17	33 12 10		125 25 21		150 30 26		ns	2.0 4.5 6.0	Figs 8 and 9
t _{su}	set-up time K̄, PĒ, D _n to CP	80 16 14	25 9 7		100 20 17		120 24 20		ns	2.0 4.5 6.0	Figs 8 and 9
t _h	hold time J, K̄, PĒ, D _n to CP	3 3 3	-8 -3 -2		3 3 3		3 3 3		ns	2.0 4.5 6.0	Figs 8 and 9
f _{max}	maximum clock pulse frequency	6 30 35	17 52 62		5 24 28		4 20 24		MHz	2.0 4.5 6.0	Fig.6

4-bit parallel access shift register

74HC/HCT195

DC CHARACTERISTICS FOR HCT

For the DC characteristics see *"74HC/HCT/HCU/HCMOS Logic Family Specifications"*.

Output capability: standard

I_{CC} category: MSI

Note to HCT types

The value of additional quiescent supply current (ΔI_{CC}) for a unit load of 1 is given in the family specifications. To determine ΔI_{CC} per input, multiply this value by the unit load coefficient shown in the table below.

INPUT	UNIT LOAD COEFFICIENT
\overline{PE}	0.65
all others	0.35

AC CHARACTERISTICS FOR 74HCT

GND = 0 V; $t_r = t_f = 6$ ns; $C_L = 50$ pF

SYMBOL	PARAMETER	T _{amb} (°C)						UNIT	TEST CONDITIONS		
		74HCT							V _{CC} (V)	WAVEFORMS	
		+25			-40 to +85		-40 to +125				
		min.	typ.	max.	min.	max.	min.				max.
t _{PHL} / t _{PLH}	propagation delay CP to Q _n		18	32		40		48	ns	4.5	Fig.6
t _{PHL}	propagation delay MR to Q _n		17	35		44		53	ns	4.5	Fig.8
t _{THL} / t _{TLH}	output transition time		7	15		19		22	ns	4.5	Fig.6
t _W	clock pulse width HIGH or LOW	20	6		25		30		ns	4.5	Fig.6
t _W	master reset pulse width LOW	16	6		20		24		ns	4.5	Fig.8
t _{rem}	removal time \overline{MR} to CP	16	6		20		24		ns	4.5	Fig.8
t _{su}	set-up time J, \overline{K} , \overline{PE} to CP	20	12		25		30		ns	4.5	Figs 8 and 9
t _{su}	set-up time D _n to CP	16	6		20		24		ns	4.5	Figs 8 and 9
t _h	hold time J, \overline{K} , \overline{PE} , D _n to CP	3	-5		3		3		ns	4.5	Figs 8 and 9
f _{max}	maximum clock pulse frequency	27	52		22		18		MHz	4.5	Fig.6

4-bit parallel access shift register

74HC/HCT195

AC WAVEFORMS

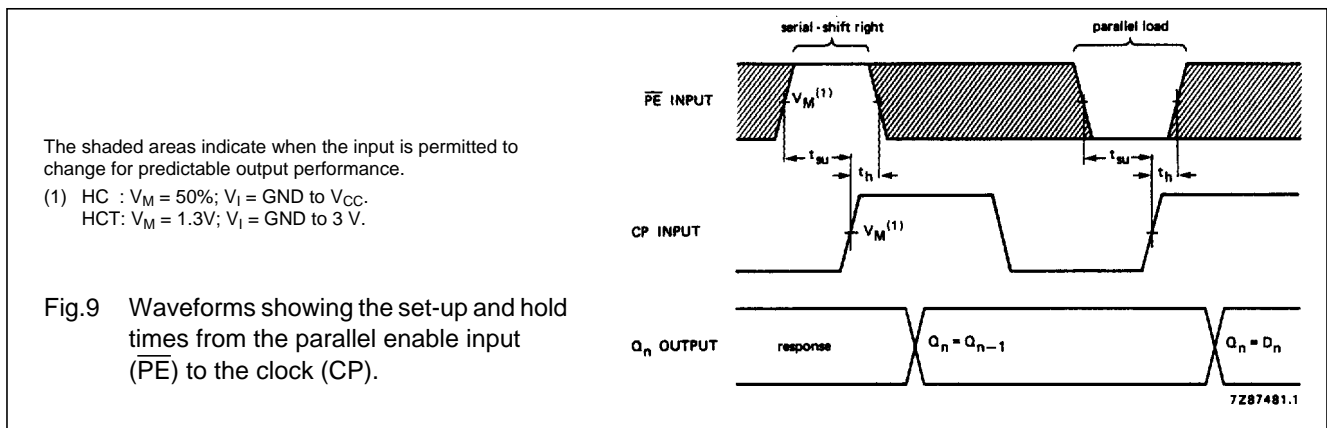
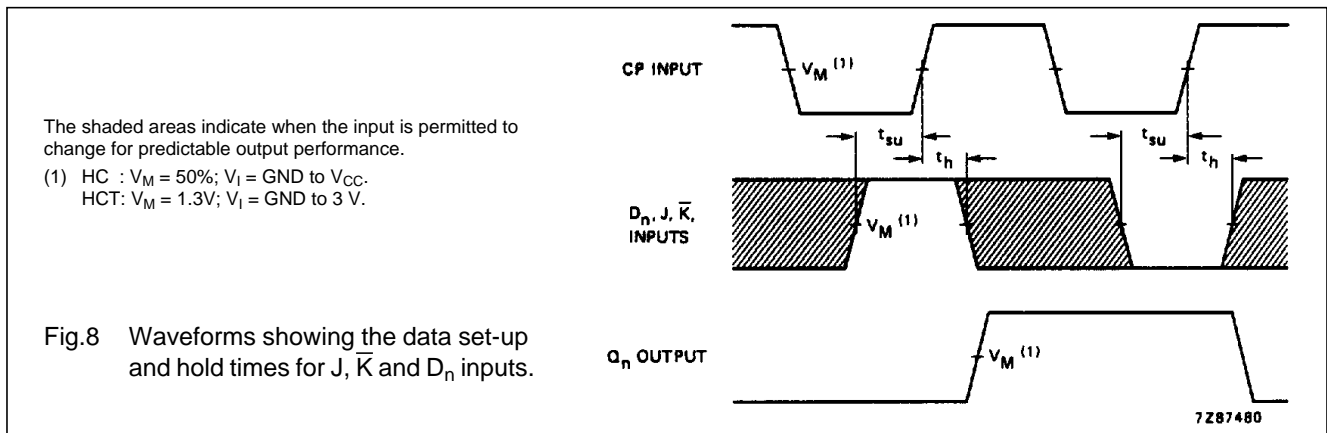
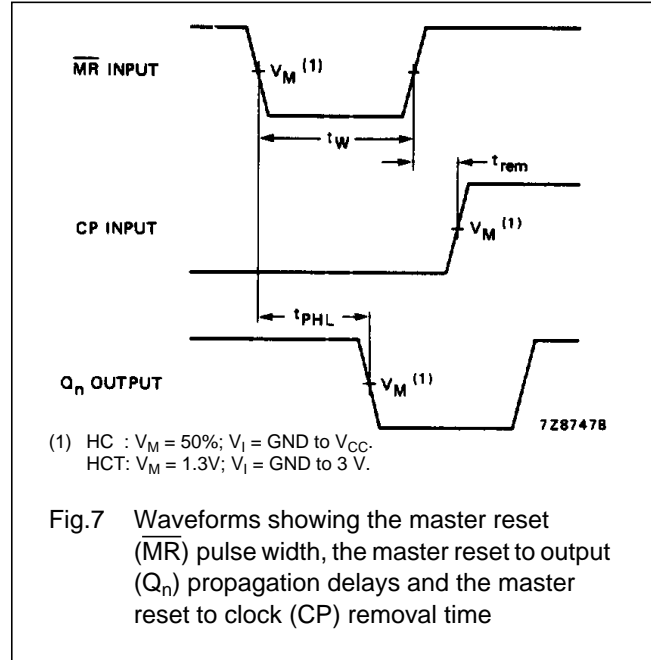
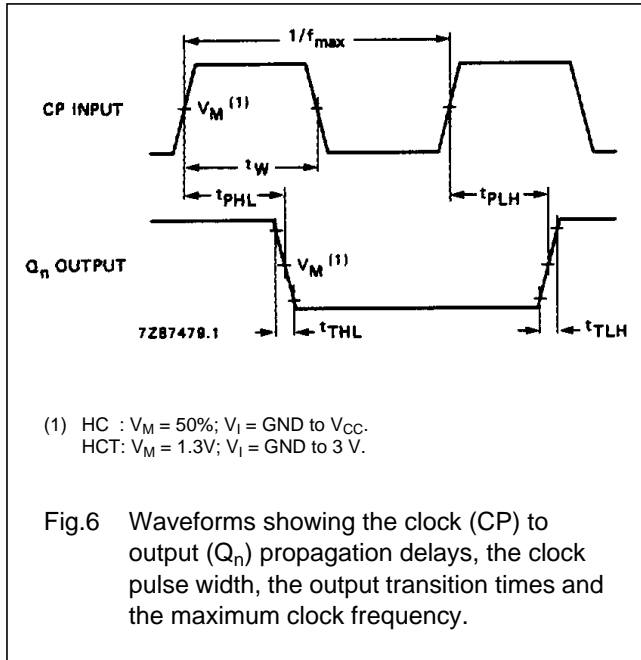

4-bit parallel access shift register

74HC/HCT195

PACKAGE OUTLINES

See *"74HC/HCT/HCU/HCMOS Logic Package Outlines"*.