

LED-010-70041



### ATTENTION

OBSERVE PRECAUTIONS  
FOR HANDLING  
ELECTROSTATIC  
DISCHARGE  
SENSITIVE  
DEVICES

### Features:

- Single color
- High bright output
- Low power consumption
- High reliability and long life

### Descriptions:

- Dice material: GaInN
- Emitting Color: Warm color white
- Device Outline:  $\phi$  5mm Round Type
- Lens Type: Water Clear

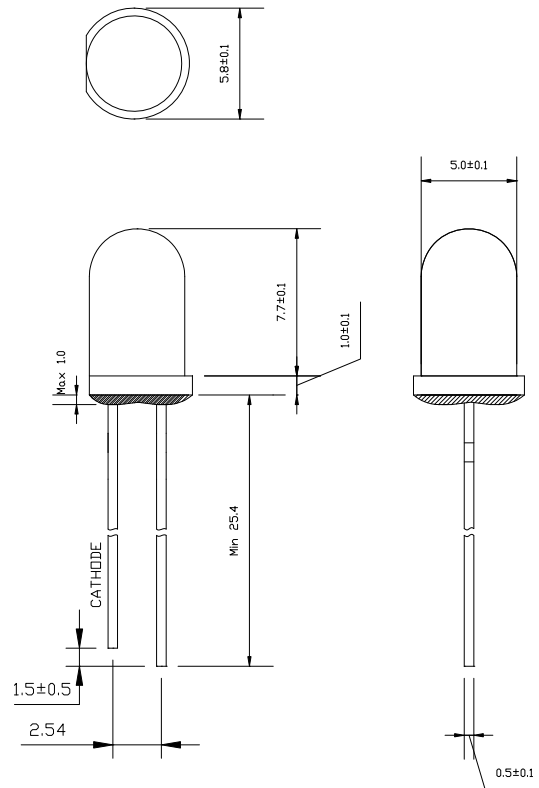

### NOTE:

- All dimensions are millimetres.
- Tolerance is  $\pm 0.25$  mm unless otherwise noted

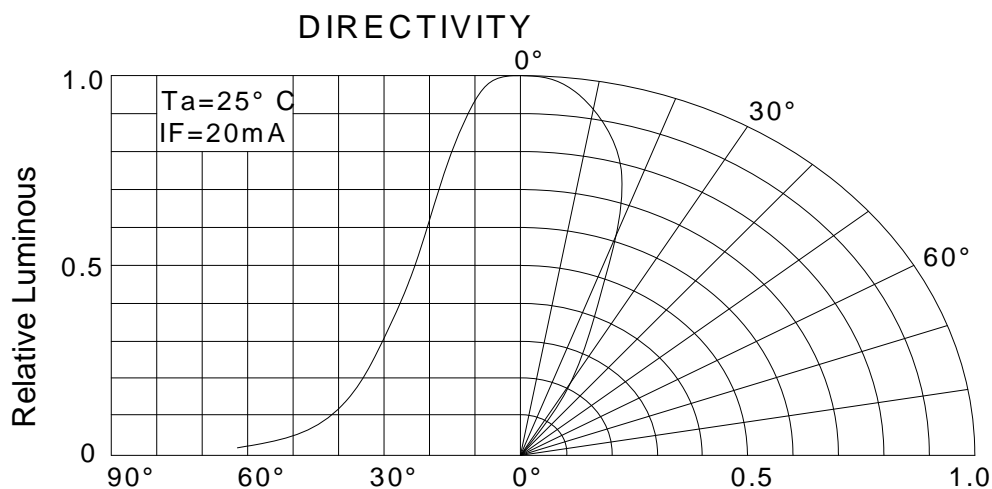

## LED SPECIFICATION

### Absolute maximum ratings (Ta = 25°C)

Parameter	Symbol	Test Condition	Value		Unit
			Min.	Max.	
Reverse Voltage	VR	IR = 30 μ A	5	--	V
Forward Current	IF	----	----	30	mA
Power Dissipation	Pd	----	----	108	mW
Pulse Current	Ipeak	Duty=0.1mS, 1kHz	----	100	mA
Operating Temperature	Topr	----	-20	+85	°C
Storage Temperature	Tstr	----	-25	+100	°C

### Electrical and optical characteristics (Ta = 25°C)

Parameter	Symbol	Test Condition	Value			Unit
			Min.	Typ.	Max.	
Forward Voltage	VF	IF = 20mA	----	3.2	3.4	V
Reverse Current	IR	VR = 5V	----	----	30	μ A
Luminous Intensity	IV	IF = 20mA	12000		18000	mcd
Viewing Angle	2 θ 1/2	IF = 20mA	13	----	17	Deg.

### Luminous Intensity Bins Chart (Ta = 25°C)

Bin	U	V	W	X	Y
Min	1500	2000	3000	4000	6000
Max	2000	3000	4000	6000	8000

### Color Temperature Bins Char (Ta = 25°C)

Bin	W0	W1	W2	W3	W4	W5
CCT	<3000	3000-3500	3500-4000	4000-4500	4500-5000	5000-6000
Bin	W6	W7	W8	W9	W10	W00
CCT	6000-7000	7000-8000	8000-10000	10000-15000	15000-20000	>20000

**Typical electrical/optical characteristic curves:**

