

TDK DC to AC Inverter CXA-L10A

4.5W , Non-Dimming Type (PCB Mountable)

TDK Standard DC/AC Inverter

DESCRIPTION :

TDK DC/AC Inverter, CXA-series, are low-noise, high frequency power sources developed for driving Cold Cathode Fluorescent Lamps operating at 20~80 kHz. These inverters are designed to handle a wide range of lamp characteristics.

FEATURES :

Constant current output ensures compatibility with a wide range of discharge lamps.

High efficiency resonant circuitry produces low-noise, sinusoidal-wave output.

One-lamp/two-lamp combined-use capability allows use in four different configurations.

Common ground or floating bulb configurations.

Compact size and light weight facilitate PC board mounting.

High Efficiency (80%)

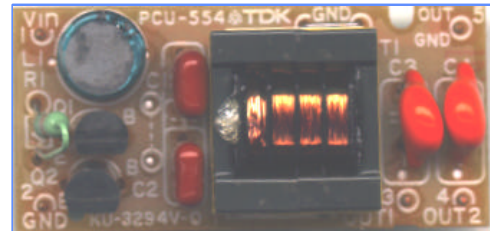

TEMPERATURE & HUMIDITY :

Operating Temperature Range 0 °C ~ +60°C

Storage Temperature Range -30 °C ~ +85°C

Humidity 95 %RH max (No dew)

APPLICATION:

Systems using LCD displays.

Facimile machine reading function.

Portable data-collection terminals.

Automotive displays.

DIMENSIONS :

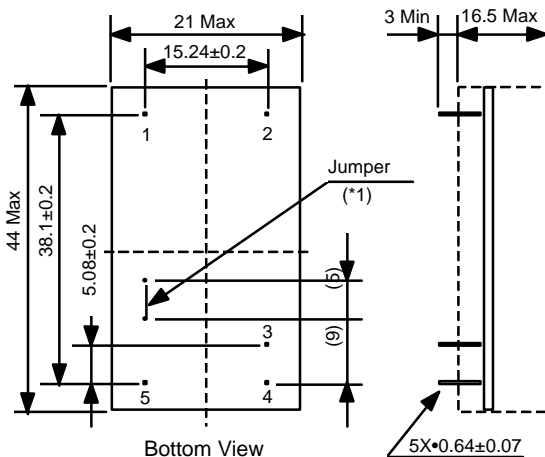

*1 Remove for Isolated Ground

Unit : mm

Pin	Symbol	Note
1	Vin	0 ~ 6 Vdc
2	GND	0 Vdc
3	lout1	
4	lout2	
5	lout-ret	

TDK DC to AC Inverter CXA-L10A

4.5W , Non-Dimming Type (PCB Mountable)

TDK Standard DC/AC Inverter

ELECTRICAL CHARACTERISTICS :

Parameters	Symbol	Conditions			Application	Specifications			Unit	Note
		Vin (V)	Ta (°C)	RL (kΩ)		min.	typ.	max.		
Output Current	lout	5±1%	23±5	30	A	9	10	11	mArms	
Input Current	lin	5±5%	0 ~ 50	22 ~ 38		8	10	12		
Frequency	FL					-	0.75	1.20	Adc	
Open Voltage	Vopen					-	30	-	kHz	
						∞	825	900	-	
Output Current	lout	5±1%	23±5	50	B	5.2	6	6.6	mArms	
Input Current	lin	5±5%	0 ~ 50	37 ~ 63		4.6	6	7.2		
Frequency	FL					-	0.48	-	Adc	
Open Voltage	Vopen					-	35	-	kHz	
						∞	825	900	-	
Output Current	lout	5±1%	23±5	60	C	4.5	5	5.6	mArms	
Input Current	lin	5±5%	0 ~ 50	45 ~ 75		4	5	6.1		
Frequency	FL					-	0.42	-	Adc	
Open Voltage	Vopen					-	30	-	kHz	
						∞	825	900	-	
Output Current	lout1	5±1%	23±5	60	D	4.5	5	5.5	mArms	
	lout2					4	5	6		
Input Current	lin	5±5%	0 ~ 50	45 ~ 75		-	0.75	-	Adc	
Frequency	FL					-	30	-	kHz	
Open Voltage	Vopen					-	30	-	kHz	
					∞	825	900	-	Vrms	

APPLICATION

