

COMPLEMENTARY SILICON POWER TRANSISTORS

APPLICATION

- LINEAR AND SWITCHING INDUSTRIAL EQUIPMENT

DESCRIPTION

The TIP31A and TIP31C are silicon Epitaxial-Base NPN transistors mounted in Jedec TO-220 plastic package. They are intended for use in medium power linear and switching applications.

The complementary PNP types are TIP32A and TIP32C respectively.

Also TIP32B is a PNP type.

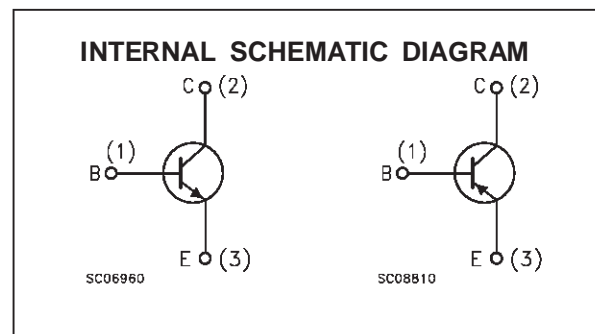
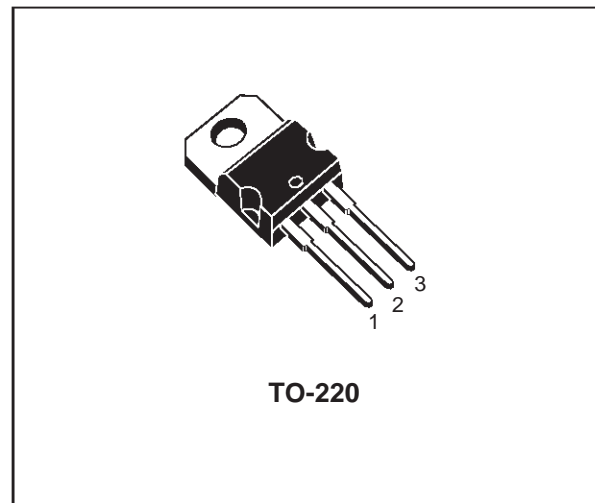

ABSOLUTE MAXIMUM RATINGS

Symbol	Parameter	Value			Unit
		NPN	TIP31A	TIP31C	
		PNP	TIP32A	TIP32C	
V_{CBO}	Collector-Base Voltage ($I_E = 0$)	60	80	100	V
V_{CEO}	Collector-Emitter Voltage ($I_B = 0$)	60	80	100	V
V_{EBO}	Emitter-Base Voltage ($I_C = 0$)	5			V
I_C	Collector Current	3			A
I_{CM}	Collector Peak Current	5			A
I_B	Base Current	1			A
P_{tot}	Total Dissipation at $T_{case} \leq 25\text{ }^\circ\text{C}$ $T_{amb} \leq 25\text{ }^\circ\text{C}$	40			W
		2			W
T_{stg}	Storage Temperature	-65 to 150			$^\circ\text{C}$
T_j	Max. Operating Junction Temperature	150			$^\circ\text{C}$

For PNP types voltage and current values are negative

TIP31A/TIP31C/TIP32A/TIP32B/TIP32C

THERMAL DATA

$R_{thj-case}$	Thermal Resistance Junction-case	Max	3.12	$^{\circ}C/W$
$R_{thj-amb}$	Thermal Resistance Junction-ambient	Max	62.5	$^{\circ}C/W$

ELECTRICAL CHARACTERISTICS ($T_{case} = 25^{\circ}C$ unless otherwise specified)

Symbol	Parameter	Test Conditions	Min.	Typ.	Max.	Unit
I_{CEO}	Collector Cut-off Current ($I_B = 0$)	for TIP31A/32A $V_{CE} = 30 V$ for TIP31C/32B/32C $V_{CE} = 60 V$			0.3 0.3	mA mA
I_{CES}	Collector Cut-off Current ($V_{BE} = 0$)	for TIP31A/32A $V_{CE} = 60 V$ for TIP/32B $V_{CE} = 80 V$ for TIP31C/32C $V_{CE} = 100 V$			0.2 0.2 0.2	mA mA mA
I_{EBO}	Emitter Cut-off Current ($I_C = 0$)	$V_{EB} = 5 V$			1	mA
$V_{CEO(sus)}^*$	Collector-Emitter Sustaining Voltage ($I_B = 0$)	$I_C = 30 mA$ for TIP31A/32A for TIP32B for TIP31C/32C	60 80 100			V V V
$V_{CE(sat)}^*$	Collector-Emitter Saturation Voltage	$I_C = 3 A$ $I_B = 375 mA$			1.2	V
$V_{BE(on)}^*$	Base-Emitter Voltage	$I_C = 3 A$ $V_{CE} = 4 V$			1.8	V
h_{FE}^*	DC Current Gain	$I_C = 1 A$ $V_{CE} = 4 V$ $I_C = 3 A$ $V_{CE} = 4 V$	25 10		50	
h_{fe}	Small Signal Current Gain	$I_C = 0.5 A$ $V_{CE} = 10 V$ $f = 1 KHz$ $I_C = 0.5 A$ $V_{CE} = 10 V$ $f = 1 MHz$	20 3			

* Pulsed : pulse duration = 300 μs , duty cycle $\leq 2\%$
For PNP types voltage and current values are negative.

Safe Operating Area

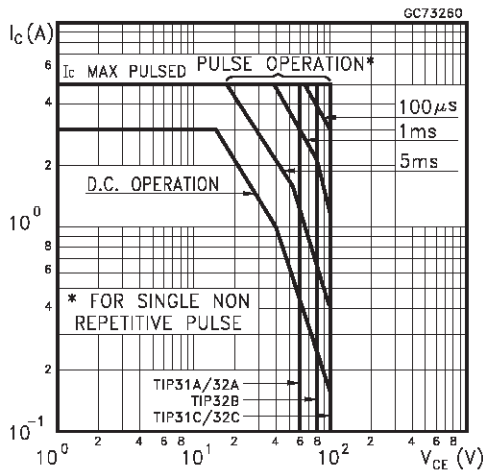

Derating Curves

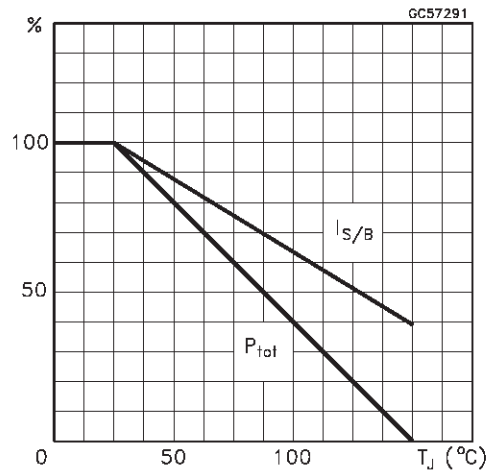

DC Current Gain (NPN type)

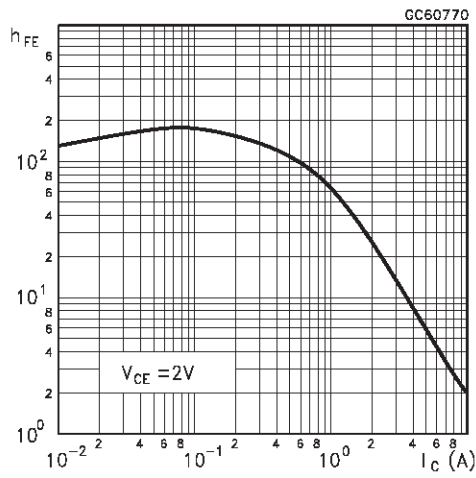

DC Current Gain (PNP type)

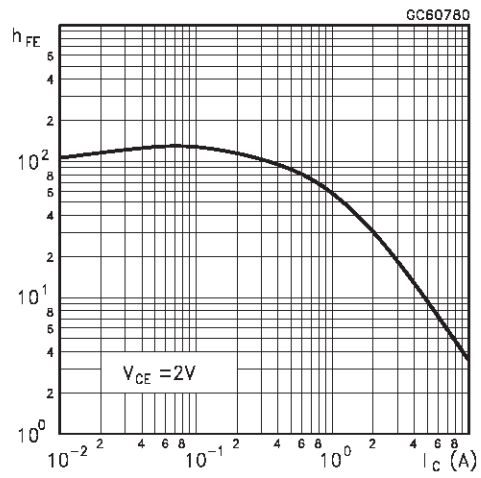

Collector-Emitter Saturation Voltage (NPN type)

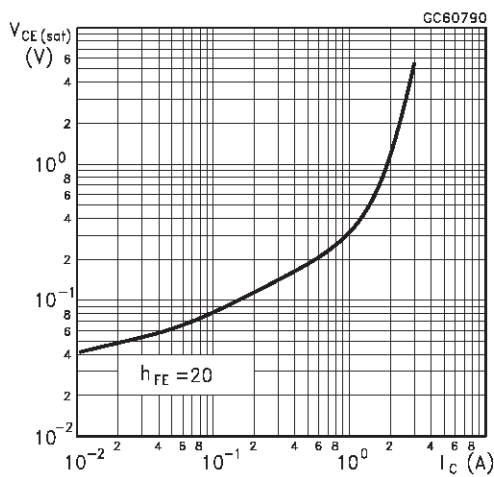

Collector-Emitter Saturation Voltage (PNP type)

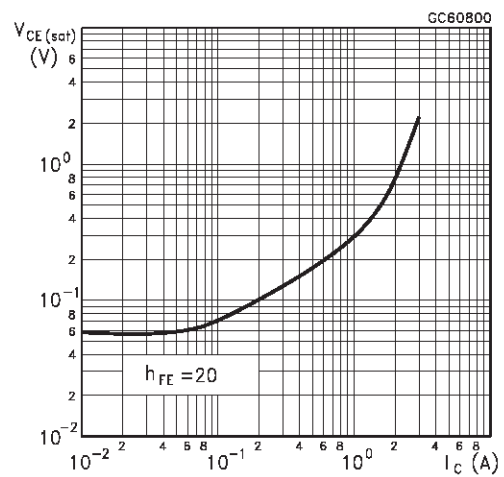

Base-Emitter Saturation Voltage (NPN type)

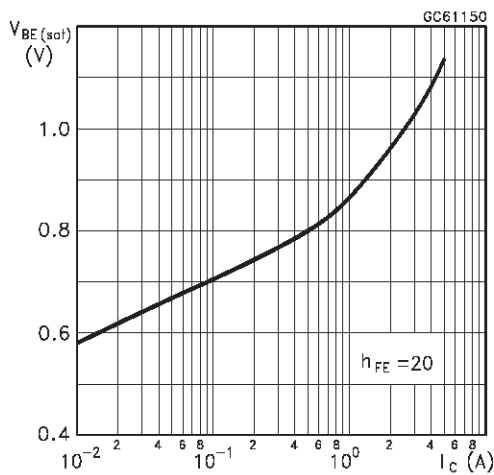

Collector-Base Capacitance (PNP type)

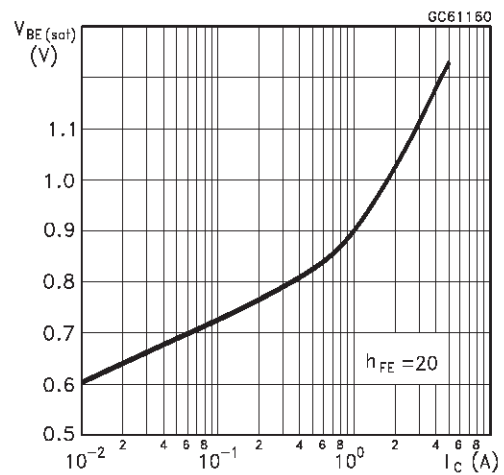

TO-220 MECHANICAL DATA

DIM.	mm			inch		
	MIN.	TYP.	MAX.	MIN.	TYP.	MAX.
A	4.40		4.60	0.173		0.181
C	1.23		1.32	0.048		0.051
D	2.40		2.72	0.094		0.107
D1		1.27			0.050	
E	0.49		0.70	0.019		0.027
F	0.61		0.88	0.024		0.034
F1	1.14		1.70	0.044		0.067
F2	1.14		1.70	0.044		0.067
G	4.95		5.15	0.194		0.203
G1	2.4		2.7	0.094		0.106
H2	10.0		10.40	0.393		0.409
L2		16.4			0.645	
L4	13.0		14.0	0.511		0.551
L5	2.65		2.95	0.104		0.116
L6	15.25		15.75	0.600		0.620
L7	6.2		6.6	0.244		0.260
L9	3.5		3.93	0.137		0.154
DIA.	3.75		3.85	0.147		0.151

