

# MJE180/181/182

**Low Power Audio Amplifier**  
**Low Current High Speed Switching Applications**

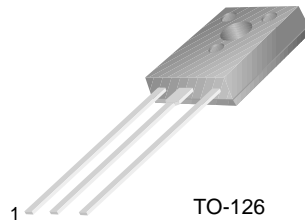

TO-126  
 1. Emitter 2. Collector 3. Base

## NPN Epitaxial Silicon Transistor

### Absolute Maximum Ratings $T_C=25^\circ\text{C}$ unless otherwise noted

Symbol	Parameter	Value	Units
$V_{CBO}$	Collector-Base Voltage : MJE180	60	V
	: MJE181	80	V
	: MJE182	100	V
$V_{CEO}$	Collector-Emitter Voltage : MJE180	40	V
	: MJE181	60	V
	: MJE182	80	V
$V_{EBO}$	Emitter-Base Voltage	7	V
$I_C$	Collector Current (DC)	3	A
$I_{CP}$	Collector Current (Pulse)	6	A
$I_B$	Base Current	1	A
$P_C$	Collector Dissipation ( $T_a=25^\circ\text{C}$ )	1.5	W
$P_C$	Collector Dissipation ( $T_C=25^\circ\text{C}$ )	12.5	W
$T_J$	Junction Temperature	150	$^\circ\text{C}$
$T_{STG}$	Storage Temperature	- 65 ~ 150	$^\circ\text{C}$

### Electrical Characteristics $T_C=25^\circ\text{C}$ unless otherwise noted

Symbol	Parameter	Test Condition	Min.	Max.	Units
$BV_{CEO}$	Collector -Emitter Breakdown Voltage	$I_C = 10\text{mA}, I_B = 0$	40		V
	: MJE180				
	: MJE181				
$I_{CBO}$	Collector Cut-off Current : MJE180	$V_{CB} = 60\text{V}, I_B = 0$		0.1	$\mu\text{A}$
	: MJE181	$V_{CB} = 80\text{V}, I_E = 0$		0.1	$\mu\text{A}$
	: MJE182	$V_{CB} = 100\text{V}, I_E = 0$		0.1	$\mu\text{A}$
	: MJE180	$V_{CB} = 60\text{V}, I_E = 0 @ T_C = 150^\circ\text{C}$		0.1	mA
	: MJE181	$V_{CB} = 80\text{V}, I_E = 0 @ T_C = 150^\circ\text{C}$		0.1	mA
	: MJE182	$V_{CB} = 100\text{V}, I_E = 0 @ T_C = 150^\circ\text{C}$		0.1	mA
$I_{EBO}$	Emitter Cut-off Current	$V_{BE} = 7\text{V}, I_C = 0$		0.1	$\mu\text{A}$
$h_{FE}$	DC Current Gain	$V_{CE} = 1\text{V}, I_C = 100\text{mA}$	50	250	
		$V_{CE} = 1\text{V}, I_C = 500\text{mA}$	30		
		$V_{CE} = 1\text{V}, I_C = 1.5\text{A}$	12		
$V_{CE(sat)}$	Collector-Emitter Saturation Voltage	$I_C = 500\text{mA}, I_B = 50\text{mA}$		0.3	V
		$I_C = 1.5\text{A}, I_B = 150\text{mA}$		0.9	V
		$I_C = 3\text{A}, I_B = 600\text{mA}$		1.7	V
$V_{BE(sat)}$	Base-Emitter Saturation Voltage	$I_C = 1.5\text{A}, I_B = 150\text{mA}$		1.5	V
		$I_C = 3\text{A}, I_B = 600\text{mA}$		2.0	V
$V_{BE(on)}$	Base-Emitter ON Voltage	$V_{CE} = 1\text{V}, I_C = 500\text{mA}$		1.2	V
$f_T$	Current Gain Bandwidth Product	$V_{CE} = 10\text{V}, I_C = 100\text{mA}$	50		MHz
$C_{ob}$	Output Capacitance	$V_{CB} = 10\text{V}, I_E = 0, f = 0.1\text{MHz}$		30	pF

# Typical Characteristics

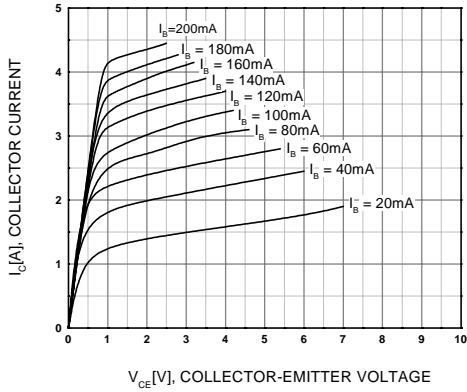

Figure 1. Static Characteristic

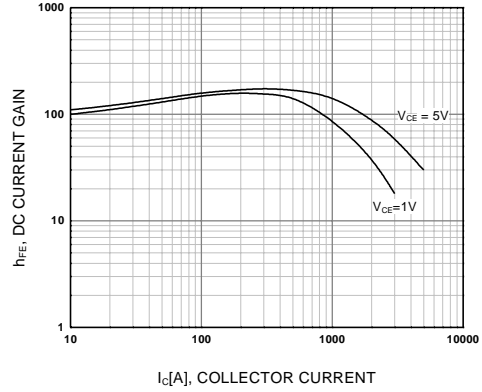

Figure 2. DC current Gain

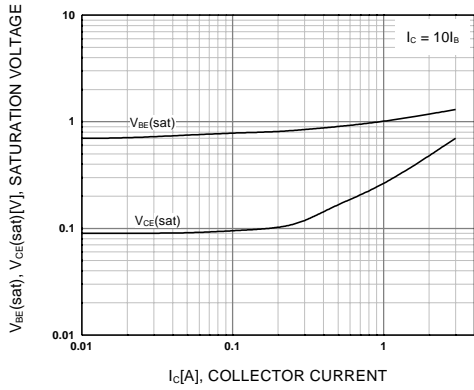

Figure 3. Base-Emitter Saturation Voltage  
Collector-Emitter Saturation Voltage

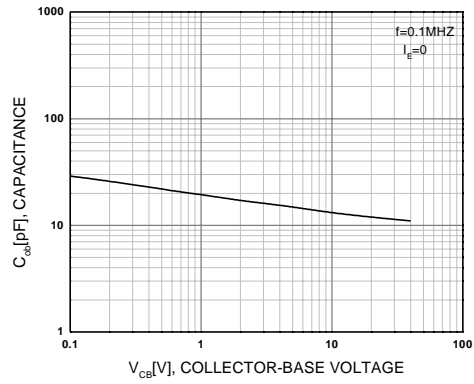

Figure 4. Collector Output Capacitance

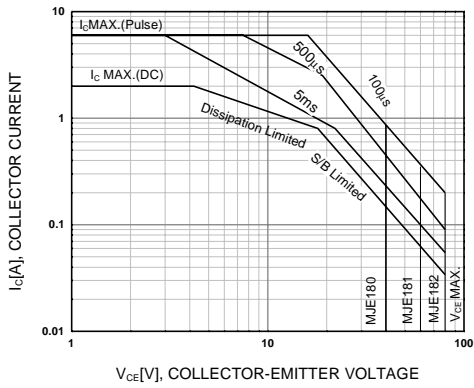

Figure 5. Safe Operating Area

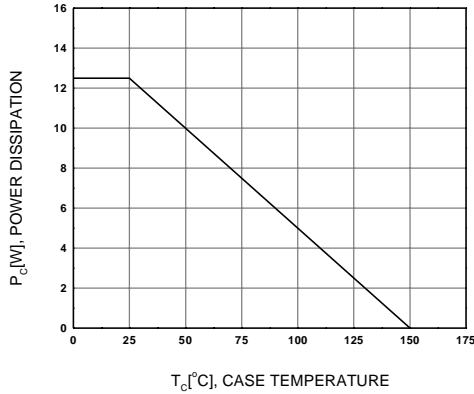
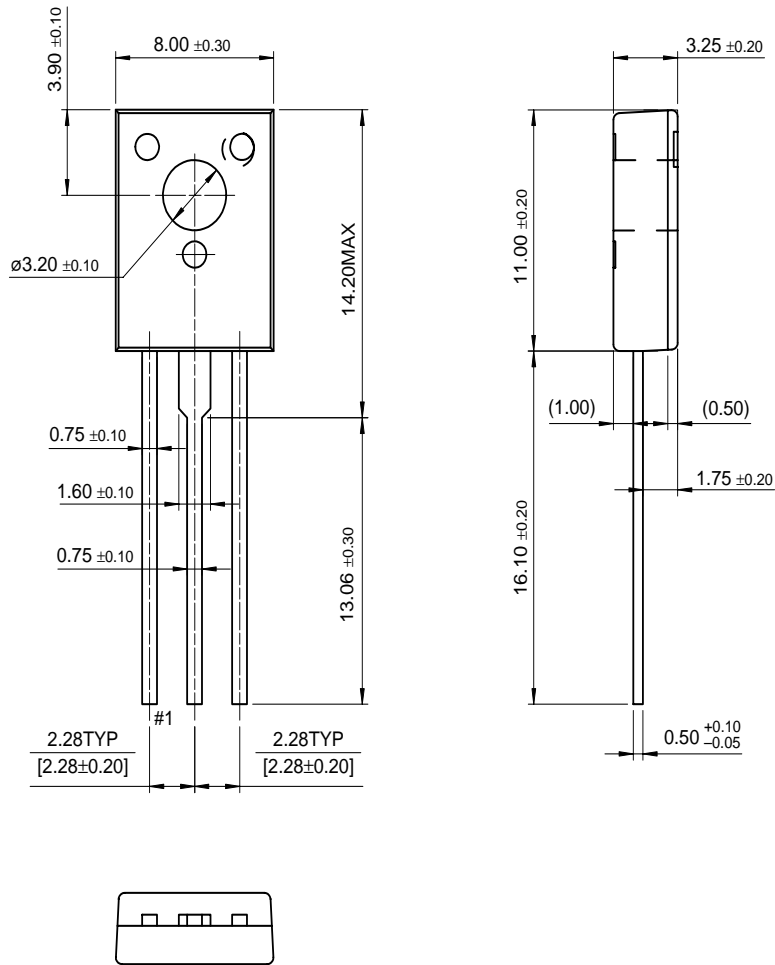

Figure 6. Power Derating

# Package Dimensions

## TO-126

MJE180/181/182



Dimensions in Millimeters