

BTA/BTB24, BTA25, BTA26 and T25 Series

SNUBBERLESS™ & STANDARD
25A TRIACs
MAIN FEATURES:

Symbol	Value	Unit
$I_{T(RMS)}$	25	A
V_{DRM}/V_{RRM}	600 and 800	V
$I_{GT}(Q_1)$	35 to 50	mA

DESCRIPTION

Available either in through-hole or surface and T25 mount packages, the BTA/BTB24-25-26 triac series is suitable for general purpose AC power switching. They can be used as an ON/OFF function in applications such as static relays, heating regulation, water heaters, induction motor starting circuits...or for phase control operation in high power motor speed controllers, soft start circuits...The snubberless versions (BTA/BTB...W and T25 series) are specially recommended for use on inductive loads, thanks to their high commutation performances.

By using an internal ceramic pad, the BTA series provides voltage insulated tab (rated at 2500V RMS) complying with UL standards (File ref.: E81734).

ABSOLUTE MAXIMUM RATINGS

Symbol	Parameter		Value	Unit
$I_{T(RMS)}$	RMS on-state current (full sine wave)	D ² PAK TO-220AB $T_c = 100^\circ\text{C}$	25	A
		RD91 TOP3 Ins. $T_c = 90^\circ\text{C}$		
		TO-220AB Ins. $T_c = 75^\circ\text{C}$		
I_{TSM}	Non repetitive surge peak on-state current (full cycle, T_j initial = 25°C)	F = 60 Hz t = 16.7 ms	260	A
		F = 50 Hz t = 20 ms	250	
I_t^2	I_t^2 Value for fusing	tp = 10 ms	340	A ² s
di/dt	Critical rate of rise of on-state current $I_G = 2 \times I_{GT}$, tr ≤ 100 ns	F = 120 Hz $T_j = 125^\circ\text{C}$	50	A/μs
V_{DSM}/V_{RSM}	Non repetitive surge peak off-state voltage	tp = 10 ms $T_j = 25^\circ\text{C}$	$V_{DRM}/V_{RRM} + 100$	V
I_{GM}	Peak gate current	tp = 20 μs $T_j = 125^\circ\text{C}$	4	A
$P_{G(AV)}$	Average gate power dissipation	$T_j = 125^\circ\text{C}$	1	W
T_{stg} T_j	Storage junction temperature range Operating junction temperature range		- 40 to + 150 - 40 to + 125	°C

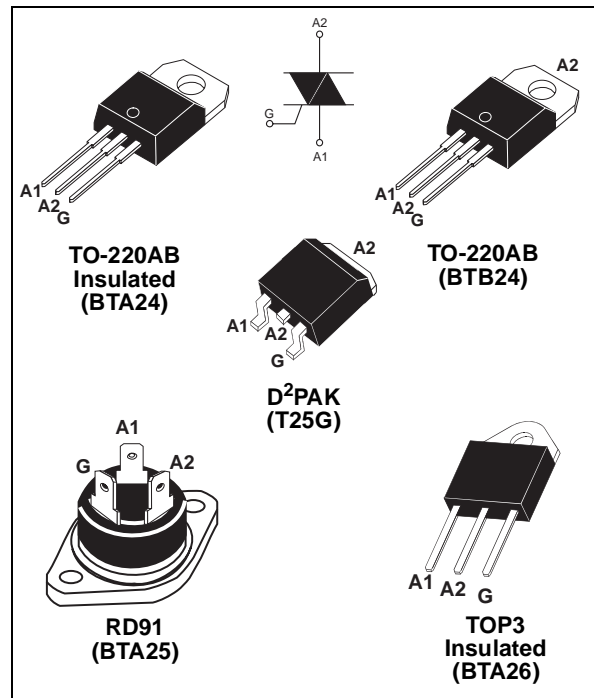

BTA/BTB24, BTA25, BTA26 and T25 Series

ELECTRICAL CHARACTERISTICS (T_j = 25°C, unless otherwise specified)

■ SNUBBERLESS™ (3 Quadrants) T25-G, BTA/BTB24...W, BTA25...W, BTA26...W

Symbol	Test Conditions	Quadrant		T25	BTA/BTB		Unit
				T2535	CW	BW	
I _{GT} (1)	V _D = 12 V R _L = 33 Ω	I - II - III	MAX.	35	35	50	mA
V _{GT}		I - II - III	MAX.	1.3			V
V _{GD}	V _D = V _{DRM} R _L = 3.3 kΩ T _j = 125°C	I - II - III	MIN.	0.2			V
I _H (2)	I _T = 500 mA		MAX.	50	50	75	mA
I _L	I _G = 1.2 I _{GT}	I - III	MAX.	70	70	80	mA
		II		80	80	100	
dV/dt (2)	V _D = 67 % V _{DRM} gate open T _j = 125°C		MIN.	500	500	1000	V/μs
(dI/dt) _c (2)	Without snubber T _j = 125°C		MIN.	13	13	22	A/ms

■ STANDARD (4 Quadrants): BTB24...B, BTA25...B, BTA26...B

Symbol	Test Conditions	Quadrant		Value	Unit
I _{GT} (1)	V _D = 12 V R _L = 33 Ω	I - II - III IV	MAX.	50 100	mA
V _{GT}		ALL	MAX.	1.3	V
V _{GD}	V _D = V _{DRM} R _L = 3.3 kΩ T _j = 125°C	ALL	MIN.	0.2	V
I _H (2)	I _T = 500 mA		MAX.	80	mA
I _L	I _G = 1.2 I _{GT}	I - III - IV	MAX.	70	mA
		II		160	
dV/dt (2)	V _D = 67 % V _{DRM} gate open T _j = 125°C		MIN.	500	V/μs
(dI/dt) _c (2)	(dI/dt) _c = 13.3 A/ms T _j = 125°C		MIN.	10	V/μs

STATIC CHARACTERISTICS

Symbol	Test Conditions		Value	Unit	
V _{TM} (2)	I _{TM} = 35 A t _p = 380 μs	T _j = 25°C	MAX.	1.55	V
V _{to} (2)	Threshold voltage	T _j = 125°C	MAX.	0.85	V
R _d (2)	Dynamic resistance	T _j = 125°C	MAX.	16	mΩ
I _{DRM} I _{RDM}	V _{DRM} = V _{RRM}	T _j = 25°C	MAX.	5	μA
		T _j = 125°C		3	mA

Note 1: minimum I_{GT} is guaranteed at 5% of I_{GT} max.

Note 2: for both polarities of A2 referenced to A1

BTA/BTB24, BTA25, BTA26 and T25 Series

THERMAL RESISTANCES

Symbol	Parameter		Value	Unit	
$R_{th(j-c)}$	Junction to case (AC)	D ² PAK TO-220AB	0.8	°C/W	
		RD91 (Insulated) TOP3 Insulated	1.1		
		TO-220AB Insulated	1.7		
$R_{th(j-a)}$	Junction to ambient	S = 1 cm ²	D ² PAK	45	°C/W
			TOP3 Insulated	50	
			TO-220AB	60	
			TO-220AB Insulated		

S: Copper surface under tab

PRODUCT SELECTOR

Part Number	Voltage (xxx)		Sensitivity	Type	Package
	600 V	800 V			
BTB24-xxxB	X	X	50 mA	Standard	TO-220AB
BTA/BTB24-xxxBW	X	X	50 mA	Snubberless	TO-220AB
BTA/BTB24-xxxCW	X	X	35 mA	Snubberless	TO-220AB
BTA25-xxxB	X	X	50 mA	Standard	RD-91
BTA25-xxxBW	X	X	50 mA	Snubberless	RD-91
BTA25-xxxCW	X	X	35 mA	Snubberless	RD-91
BTA26-xxxB	X	X	50 mA	Standard	TOP3 Ins.
BTA26-xxxBW	X	X	50 mA	Snubberless	TOP3 Ins.
BTA26-xxxCW	X	X	35 mA	Snubberless	TOP3 Ins.
T2535-xxxG	X	X	35 mA	Snubberless	D ² PAK

BTB: Non insulated TO-220AB package

ORDERING INFORMATION

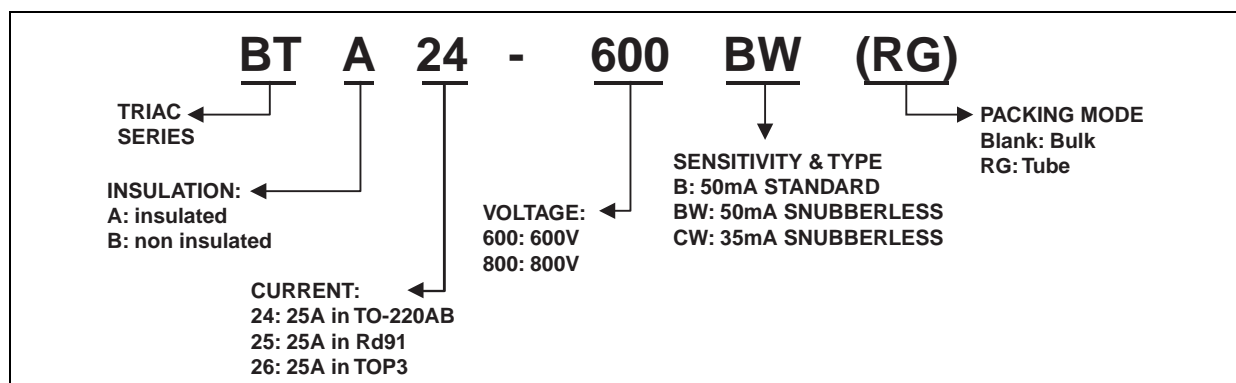

BTA/BTB24, BTA25, BTA26 and T25 Series

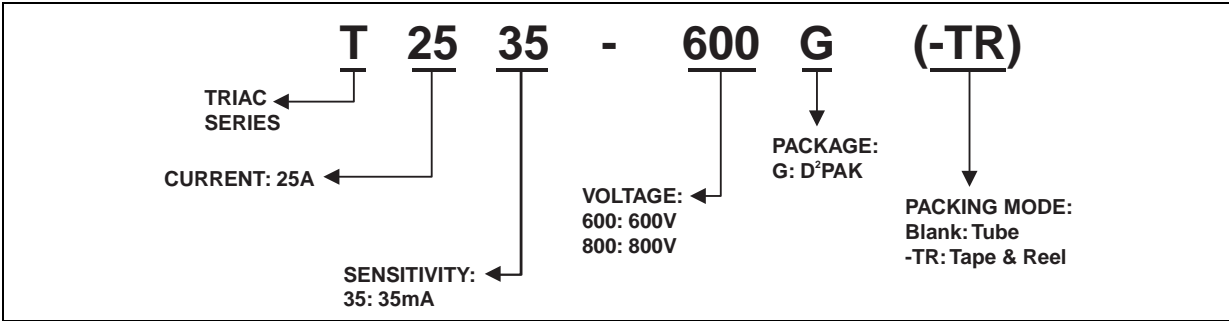

Fig. 1: Maximum power dissipation versus RMS on-state current (full cycle).

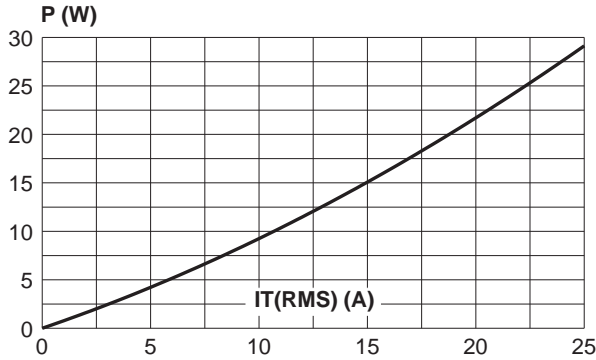

Fig. 2-1: RMS on-state current versus case temperature (full cycle).

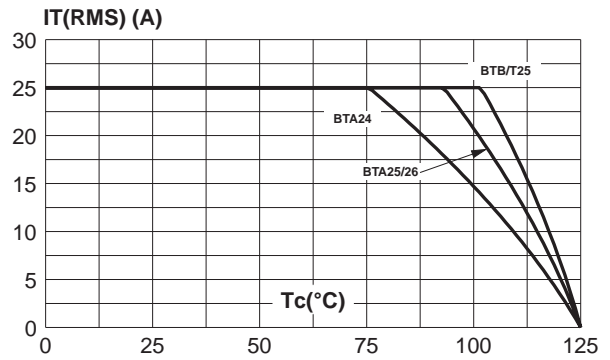

Fig. 2-2: D²PAK RMS on-state current versus ambient temperature (printed circuit board FR4, copper thickness: 35 μm), full cycle.

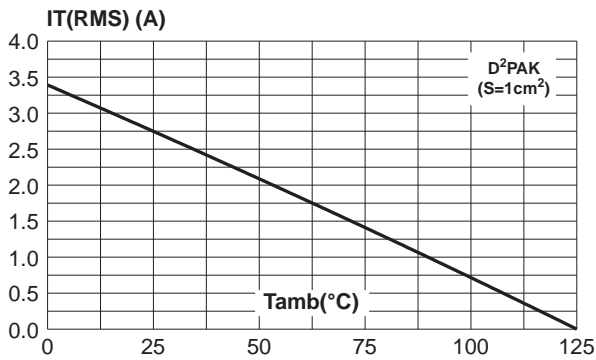

Fig. 3: Relative variation of thermal impedance versus pulse duration.

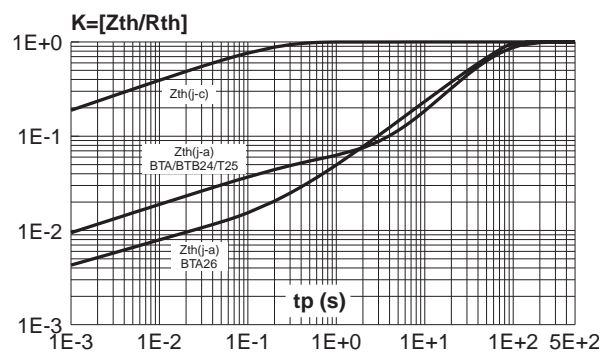

Fig. 4: On-state characteristics (maximum values).

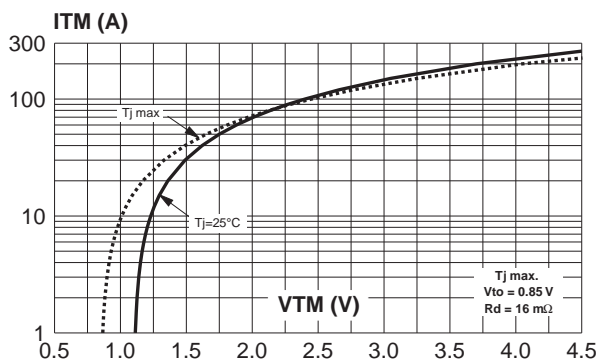
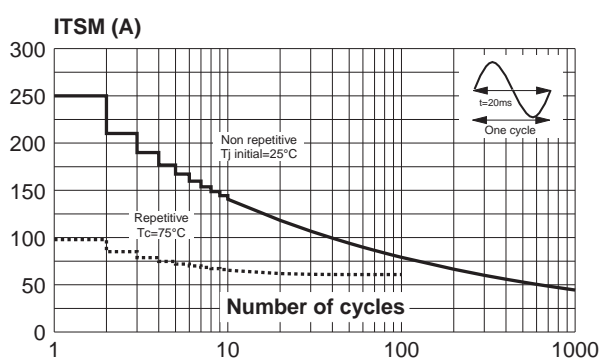

Fig. 5: Surge peak on-state current versus number of cycles.



BTA/BTB24, BTA25, BTA26 and T25 Series

Fig. 6: Non-repetitive surge peak on-state current for a sinusoidal pulse with width $t_p < 10\text{ms}$, and corresponding value of I^2t .

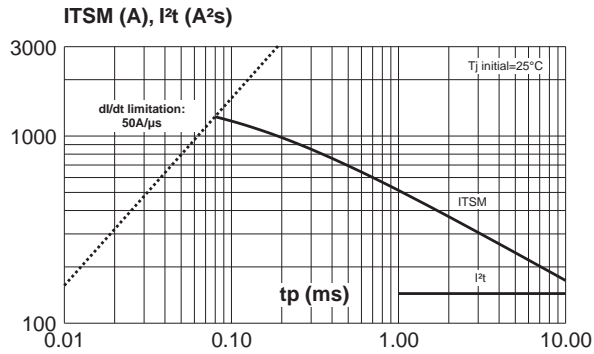

Fig. 8: Relative variation of critical rate of decrease of main current versus $(dV/dt)_c$ (typical values).

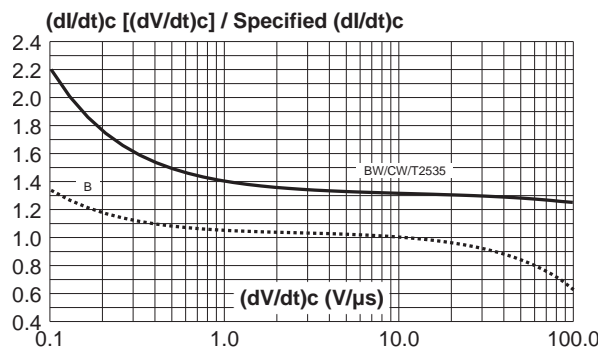

Fig. 10: D²PAK Thermal resistance junction to ambient versus copper surface under tab (printed circuit board FR4, copper thickness: 35 μm).

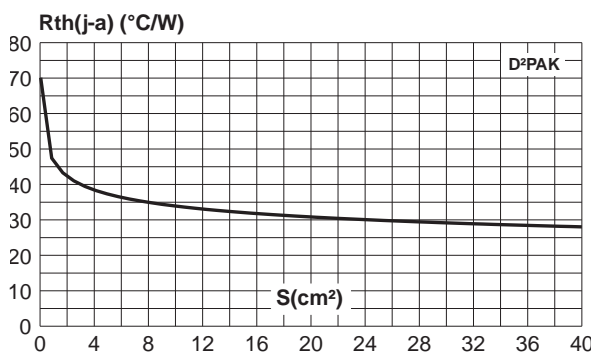

Fig. 7: Relative variation of gate trigger current, holding current and latching current versus junction temperature (typical values).

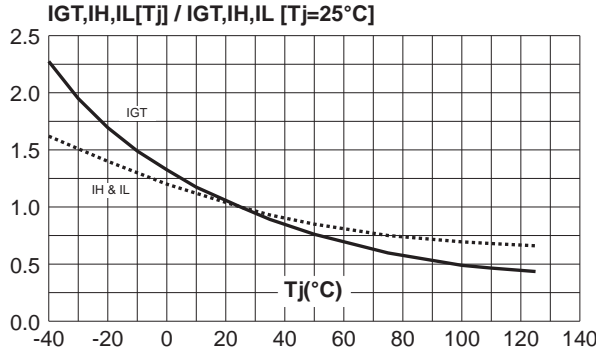
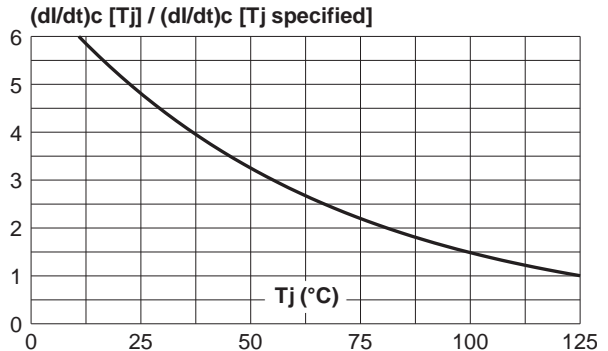
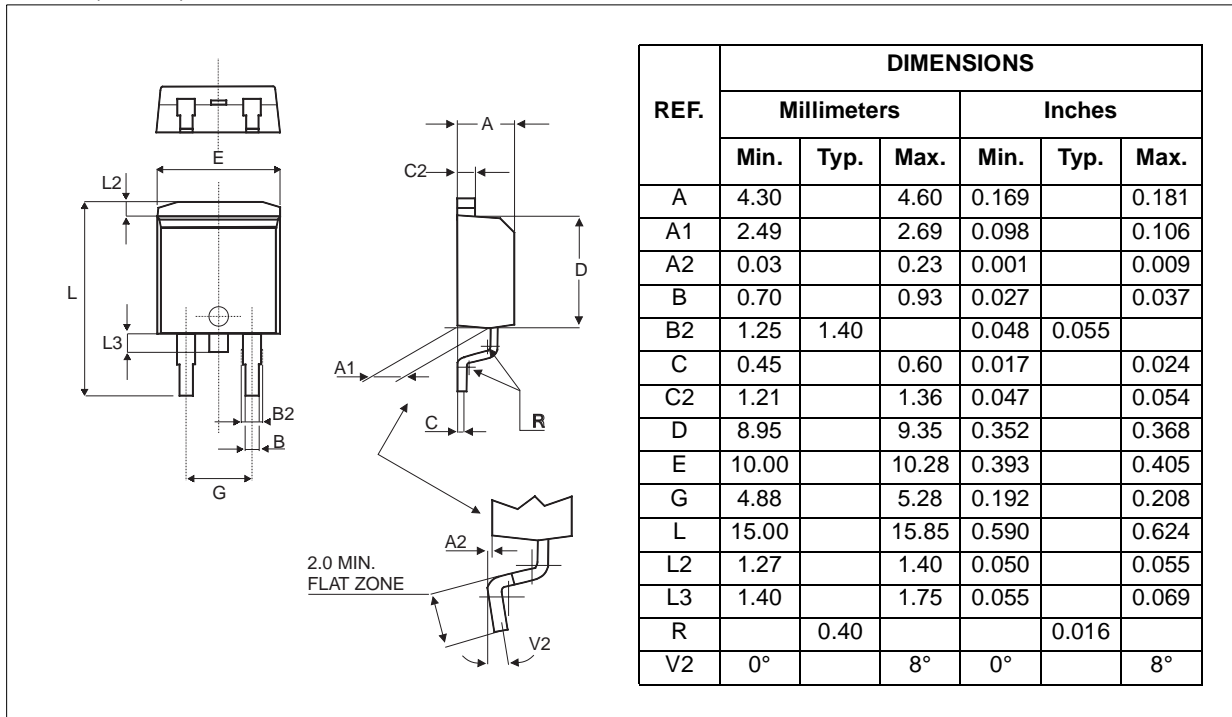

Fig. 9: Relative variation of critical rate of decrease of main current versus junction temperature.



PACKAGE MECHANICAL DATA

D²PAK (Plastic)



FOOTPRINT DIMENSIONS (in millimeters)

D²PAK (Plastic)

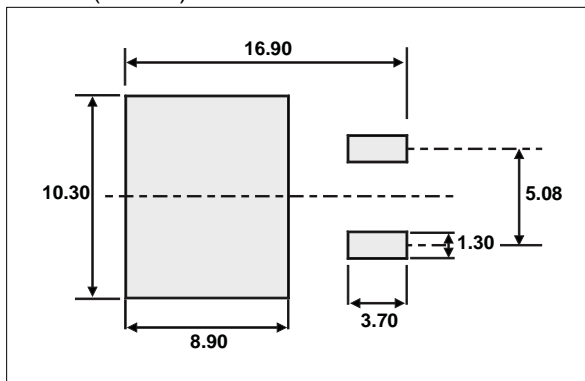

BTA/BTB24, BTA25, BTA26 and T25 Series

PACKAGE MECHANICAL DATA

RD91 (Plastic)

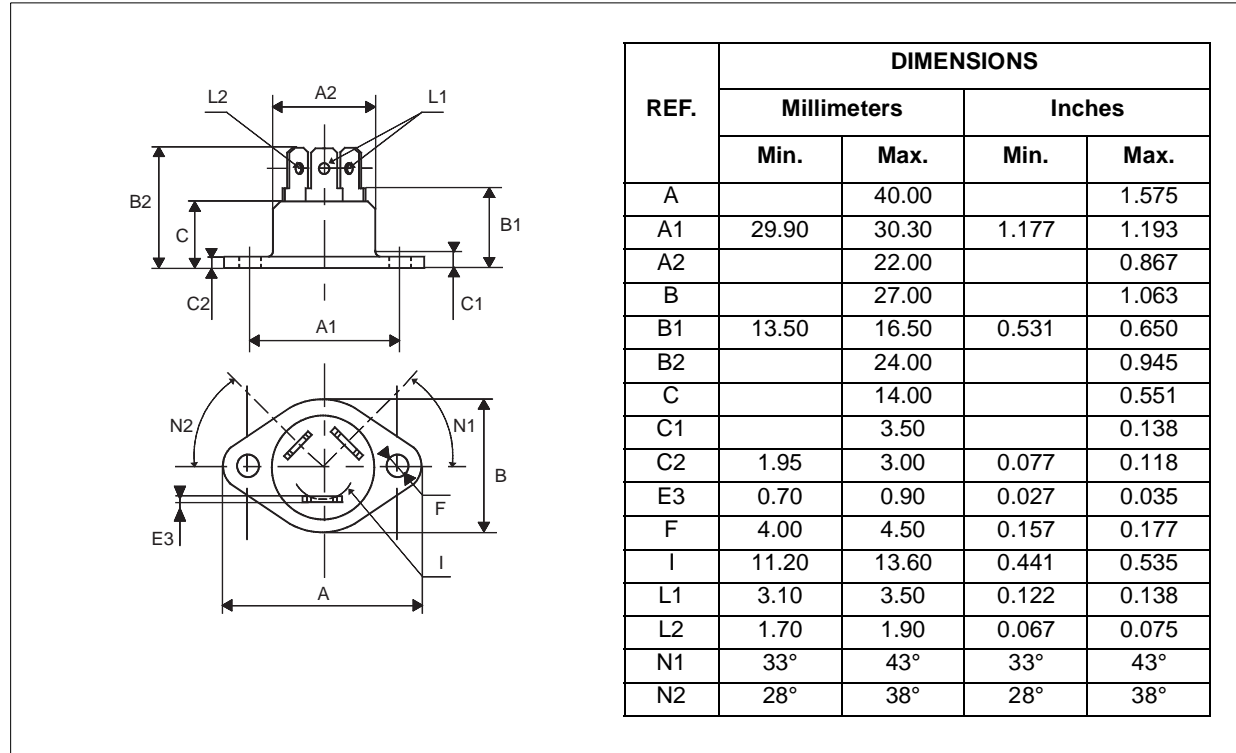

PACKAGE MECHANICAL DATA

TOP3 (Plastic)

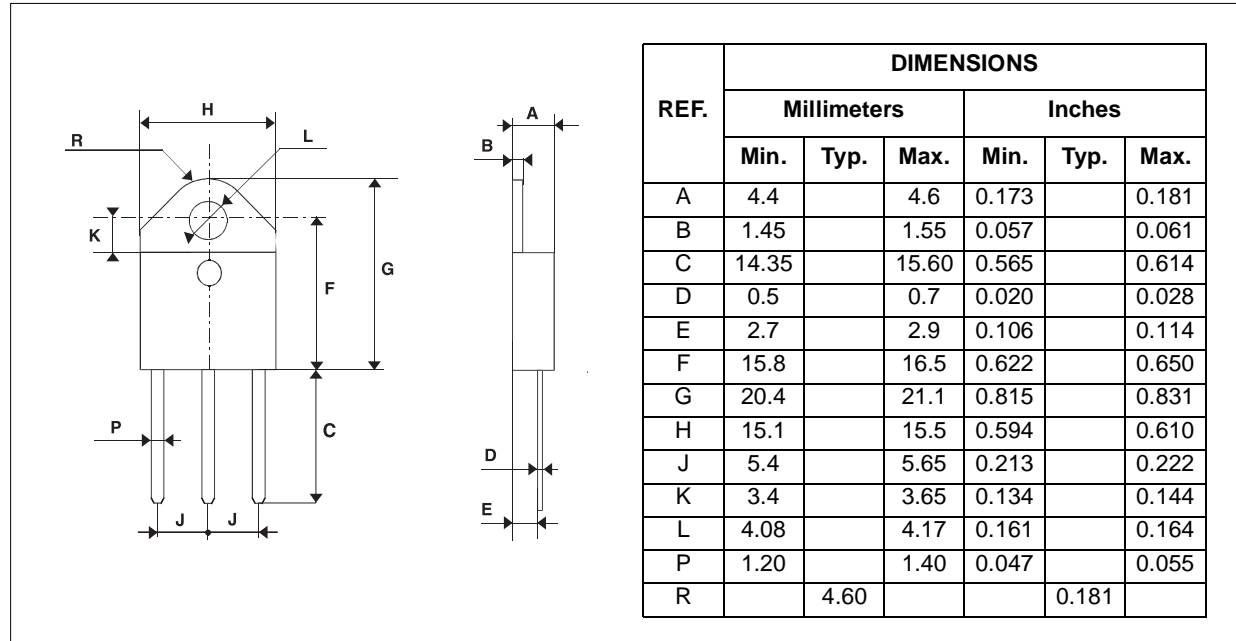

PACKAGE MECHANICAL DATA

TO-220AB (Plastic)

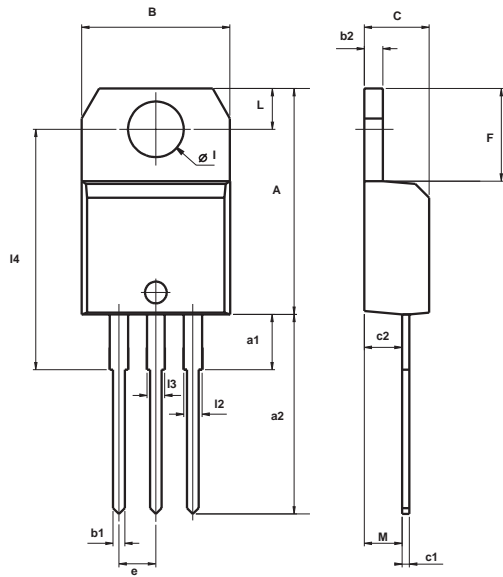

REF.	DIMENSIONS					
	Millimeters			Inches		
	Min.	Typ.	Max.	Min.	Typ.	Max.
A	15.20		15.90	0.598		0.625
a1		3.75			0.147	
a2	13.00		14.00	0.511		0.551
B	10.00		10.40	0.393		0.409
b1	0.61		0.88	0.024		0.034
b2	1.23		1.32	0.048		0.051
C	4.40		4.60	0.173		0.181
c1	0.49		0.70	0.019		0.027
c2	2.40		2.72	0.094		0.107
e	2.40		2.70	0.094		0.106
F	6.20		6.60	0.244		0.259
l	3.75		3.85	0.147		0.151
I4	15.80	16.40	16.80	0.622	0.646	0.661
L	2.65		2.95	0.104		0.116
l2	1.14		1.70	0.044		0.066
l3	1.14		1.70	0.044		0.066
M		2.60			0.102	