



LED-040-75079

Features:

- Highest Flux White
- High reliability and Very long operating life (up to 100K hours)
- Low voltage DC operated
- More Energy Efficient than Incandescent and most Halogen lamps
- NO UV
- Superior ESD protection

Typical Applications:

- Reading lights(car,bus,aircraft)
- Portable(flashlight,bicycle)
- Automotive Exterior(Stop-Tail-Turn, CHMSL,Mirror Side Repeat)
- Decorative

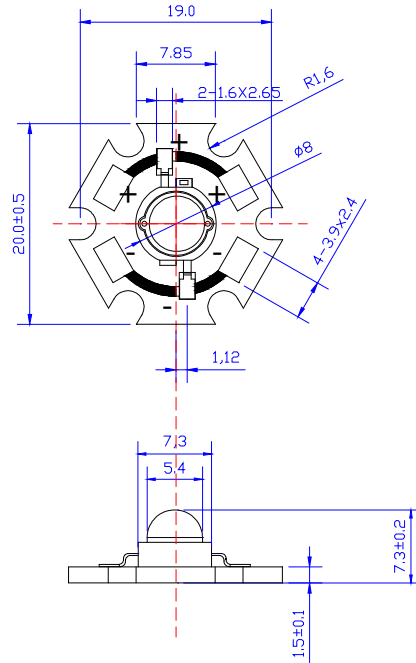

NOTE:

- All dimensions are millimetres.
- Tolerance is ± 0.1 mm unless otherwise noted

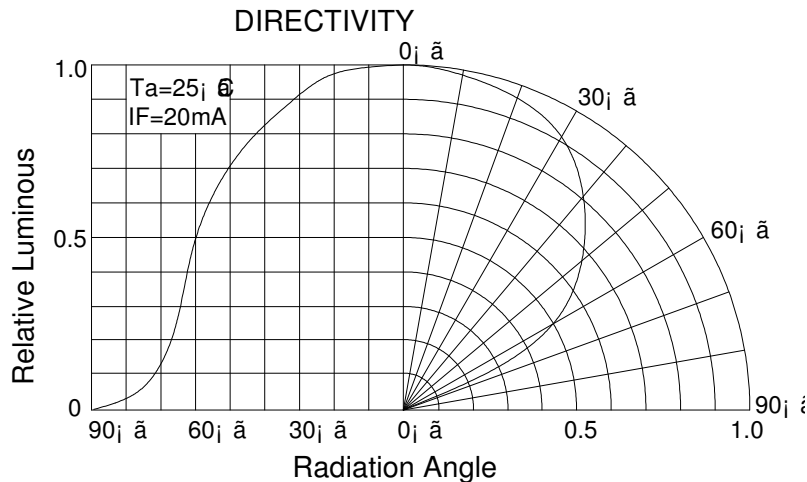

STAR I

Absolute maximum ratings (Ta = 25°C)

Parameter	Symbol	Test Condition	Value		Unit
			Min.	Max.	
DC Forward Current	IF	----	----	350	mA
Peak Pulse Current	Ipeak	Duty=0.1mS, 1kHz	----	500	mA
Power Dissipation	Pd	----	----	1.4	W
LED Junction Temperature	Tj	----		120	°C
Operating Temperature	Topr	----	-25	+100	°C
Storage Temperature	Tstr	----	-40	+120	°C
ESD Sensitivity	---	HBM	8000	---	V
Soldering Temperature	---	-----	260°C for 5 Seconds max		

Electrical and optical characteristics (Ta = 25°C)

Parameter	Symbol	Test Condition	Value			Unit
			Min.	Typ.	Max.	
Forward Voltage	VF	IF = 350mA	----	3.5	4.0	V
Luminous Flux	Φv	IF = 350mA	25	30	-	lm
Viewing Angle	2θ 1/2	IF = 350mA	----	120	----	Deg.
Color Temperature	CCT	IF = 350mA	6500	----	8000	K
Chromaticity Coordinates	X,Y	IF = 350mA	WC			--

Luminous Flux Bins (Ta = 25°C)

Unit:lm

Bin	C	D	E	F	G	H
Min	10	15	20	25	30	40
Max	15	20	25	30	40	50

Dominant Wavelength- λd (Ta = 25°C)

Unit: nm

Bin	B	C	D	E		
Min	8000K	6500K	5000K	3500K		
Max	10000K	8000K	6500K	5000K		

STAR I

Chromaticity Coordinates Ranks (IF=20mA Ta=25°C)

WA	X	0.240	0.235	0.265	0.270	WC	X	0.300	0.300	0.330	0.330
	Y	0.210	0.248	0.295	0.240		Y	0.280	0.335	0.360	0.310
WB	X	0.270	0.265	0.300	0.300	WD	X	0.330	0.330	0.360	0.360
	Y	0.240	0.295	0.335	0.280		Y	0.310	0.360	0.385	0.345

CIE 1931 Chromaticity diagram

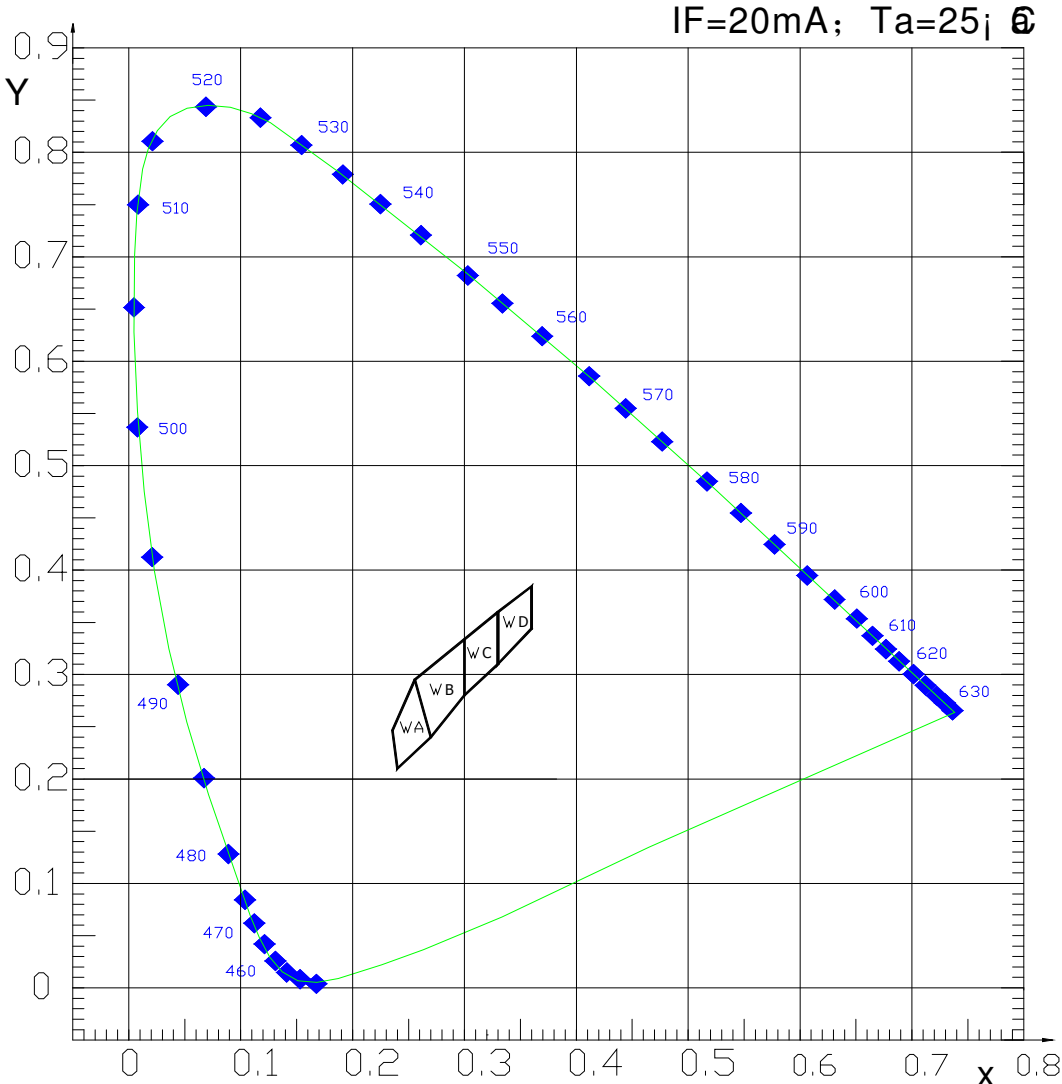

Typical electrical/optical characteristic curves:

