



LED-040-60078

Features:

- Highest Flux Blue
- High reliability and Very long operating life (up to 100K hours)
- Low voltage DC operated
- More Energy Efficient than Incandescent and most Halogen lamps
- Superior ESD protection
-

Typical Applications:

- Decorative
- Portable (flashlight, bicycle)
- Automotive Exterior (Stop-Tail-Turn, CHMSL, Mirror Side Repeat)
-

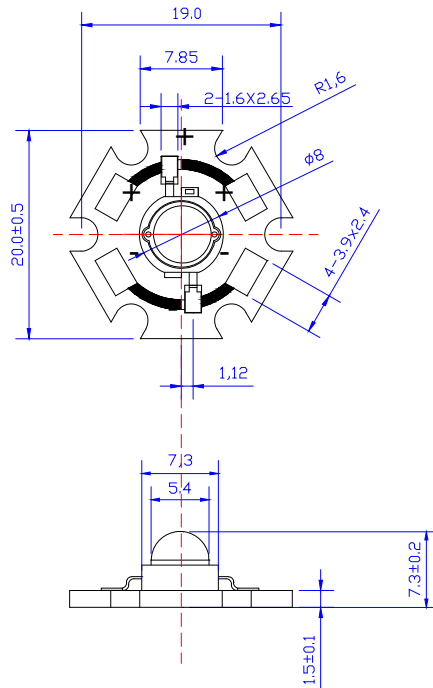

NOTE:

- All dimensions are millimetres.
- Tolerance is ± 0.1 mm unless otherwise noted

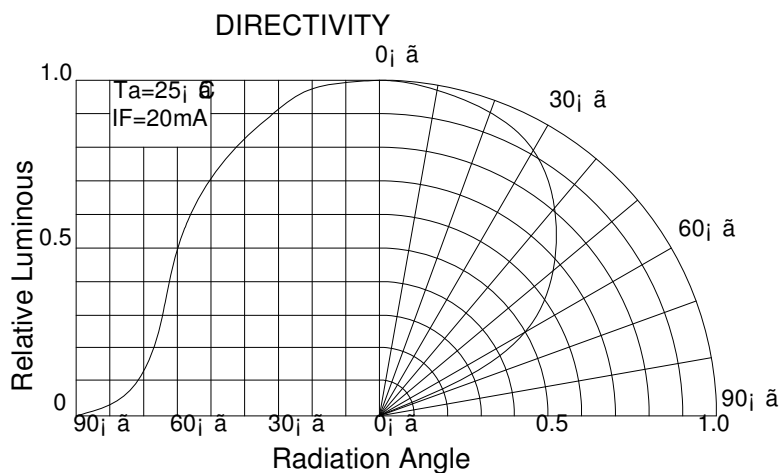

STAR I

Absolute maximum ratings (Ta = 25°C)

| Parameter | Symbol | Test Condition | Value | | Unit |
|--------------------------|--------|------------------|-------------------------|------|------|
| | | | Min. | Max. | |
| DC Forward Current | IF | ---- | ---- | 350 | mA |
| Peak Pulse Current | Ipeak | Duty=0.1mS, 1kHz | ---- | 500 | mA |
| Power Dissipation | Pd | ---- | ---- | 1.4 | W |
| LED Junction Temperature | Tj | ---- | | 120 | °C |
| Operating Temperature | Topr | ---- | -25 | +100 | °C |
| Storage Temperature | Tstr | ---- | -40 | +120 | °C |
| ESD Sensitivity | --- | HBM | 8000 | --- | V |
| Soldering Temperature | --- | ----- | 260°C for 5 Seconds max | | |

Electrical and optical characteristics (Ta = 25°C)

| Parameter | Symbol | Test Condition | Value | | | Unit |
|---------------------|--------|----------------|-------|------|------|------|
| | | | Min. | Typ. | Max. | |
| Forward Voltage | VF | IF = 350mA | ---- | 3.5 | 4.0 | V |
| Luminous Flux | Φv | IF = 350mA | 5 | 8 | 10 | lm |
| Viewing Angle | 2θ 1/2 | IF = 350mA | ---- | 120 | ---- | Deg. |
| Dominant Wavelength | λd | IF = 350mA | 460 | ---- | 470 | nm |

Luminous Flux Bins (Ta = 25°C)

Unit:lm

| Bin | B | C | D | E | F | G |
|-----|----|----|----|----|----|----|
| Min | 5 | 10 | 15 | 20 | 25 | 30 |
| Max | 10 | 15 | 20 | 25 | 30 | 40 |

Dominant Wavelength- λd (Ta = 25°C)

Unit: nm

| Bin | F | G | H | I | J | |
|-----|-----|-----|-----|-----|-----|--|
| Min | 455 | 460 | 465 | 470 | 475 | |
| Max | 460 | 465 | 470 | 475 | 480 | |

Typical electrical/optical characteristic curves:

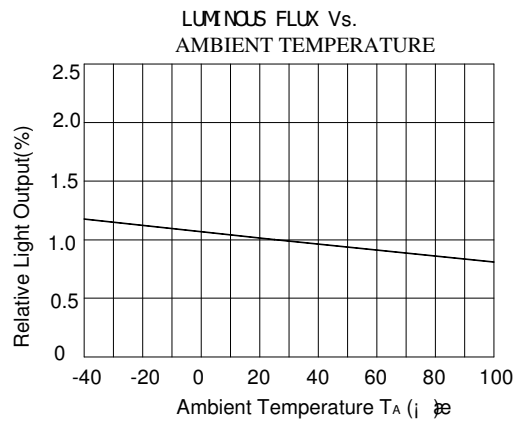
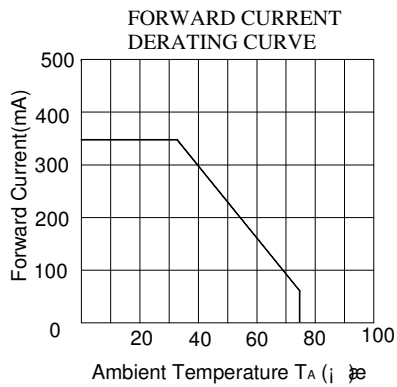
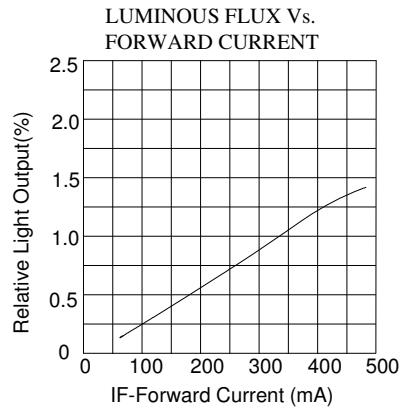
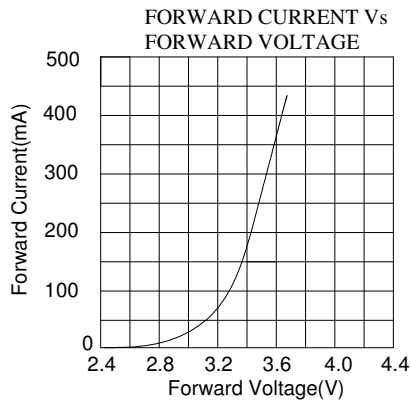

465/20

